



SERVICE MANUAL 12VDC WALL THERMOSTAT AIR CONDITIONING SYSTEMS ROOFTOP UNITS ONLY

! WARNING - SHOCK HAZARD!

TO PREVENT THE POSSIBILITY OF SEVERE PERSONAL INJURY, DEATH, OR EQUIPMENT DAMAGE DUE TO ELECTRICAL SHOCK, ALWAYS BE SURE THE POWER SUPPLY TO THE APPLIANCE IS DISCONNECTED BEFORE DOING ANY WORK ON THE APPLIANCE. THIS CAN NORMALLY BE ACCOMPLISHED BY SWITCHING THE BREAKER FOR THE AIR CONDITIONER TO OFF, DISCONNECTING ALL EXTERNAL ELECTRICAL CONNECTIONS AND CORDS, SWITCHING ON BOARD ELECTRICAL GENERATORS AND INVERTERS TO OFF, AND REMOVING THE CABLE FROM EACH POSITIVE TERMINAL ON ALL STORAGE AND STARTING BATTERIES.

DANGER

SOME DIAGNOSTIC TESTING MAY BE DONE ON ENERGIZED CIRCUITS. ELECTRICAL SHOCK CAN OCCUR IF NOT TESTED PROPERLY. TESTING TO BE DONE BY QUALIFIED TECHNICIANS ONLY

The steps outlined in this manual are intended to guide the service technician through the process of correctly diagnosing a Coleman Mach series rooftop air conditioner with a remote wall thermostat control system.

TABLE OF CONTENTS

	PAGE
I. INTRODUCTION TO WALL THERMOSTATS	3
II INTRODUCTION TO RELAYS	5
HOW DO RELAYS FUNCTION	5
III CHECKING CEILING PLENUMS WITH INDIVIDUAL RELAYS	6
IV CHECKING CEILING PLENUMS WITH PRINTED CIRCUIT BOARDS	8
CHECKING THE THERMOSTAT OPERATION	9
CHECKING THE PRINTED CIRCUIT BOARD OPERATION	10
V DIAGNOSTIC FLOW CHARTS	11
VI WIRING DIAGRAMS	16

I. INTRODUCTION TO WALL THERMOSTATS

All of the air conditioning functions are controlled by the wall mounted thermostat . These thermostats utilize a **12 VDC** electrical circuit which is supplied by the vehicle manufacture or the installer of the A/C unit. Most of the thermostats provided by Recreation Vehicle Products are combination (Heat / Cool) thermostats. These thermostats are capable of operating both the roof top air conditioner and any furnace with a **12 VDC** control circuit.

The Figures below list three of the most commonly found Coleman/RV Products Wall Mounted Thermostats for rooftop air conditioners (heat pumps excluded). These thermostats are listed in chronological order from the oldest to the newest.

1. Mechanical / By-Metal Thermostats

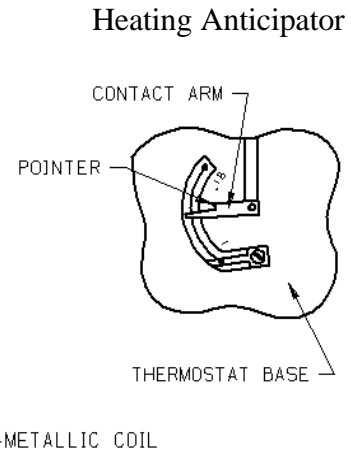
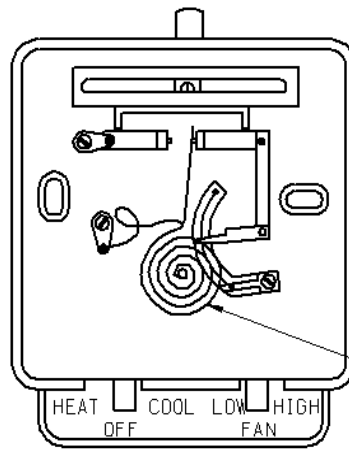
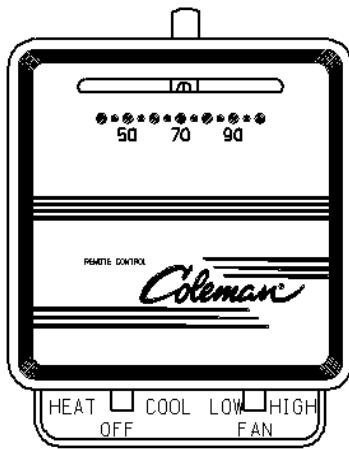

Heating Anticipator

2. Electronic Thermostats

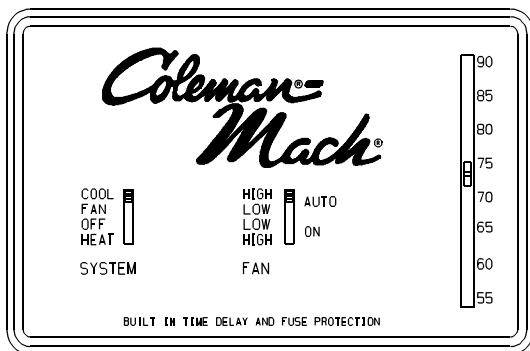

3. Electronic Digital Display Thermostats

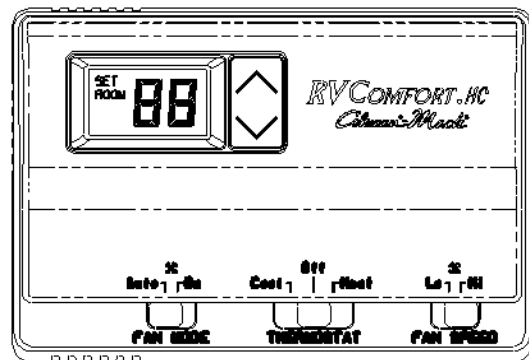

NOTE:

ALL THREE OF THESE THERMOSTATS ARE COMPLETELY INTERCHANGEABLE.

Thermostats are really nothing more than temperature controlled switches. When the need for Cooling or Heating exists the thermostat sends a 12VDC(+) signal to the control relays or a P.C. board which in turn energizes the air conditioner components or the furnace. (Note: Relays and P.C. boards will be further discussed later in lesson II).

The following chart shows the different electrical connections made by the thermostat during operation. The chart below assumes 12VDC(+) is supplied to thermostat Red wire “R” and that 12VDC(-) or ground is supplied to the Blue wire “B” at all times.

Thermostat Operations	Internal 12VDC(+) Connections Made
Cool Mode Selected On Low Fan	Red “R” to Yellow “Y” and Gray “GL”
Cool Mode Selected On High Fan	Red “R” to Yellow “Y” and Green “GH”
Heat Mode Selected On Any Fan Speed (Note: Furnace blower operates independently from sequencer or time delay in furnace)	Red “R” to White “W”
Fan Only Selected (Hi-Fan Only)	Red “R” to Green “GH”

Note: When the auto cool mode is selected on the thermostat the fan cycles “on” and “off” with the compressor as needed. When the on cool mode has been selected the fan runs continuously and the compressor cycles “on” and “off” as needed.

The following chart depicts thermostat wiring and the wiring destinations for air conditioners with control boxes containing Printed Circuit Boards.

THERMOSTAT TERMINAL / WIRE	CONTROL AND SUPPLY WIRING (OEM / VENDOR)	CEILING ASSEMBLY TERMINAL DESIGNATION
R or RED	ONE RED, (+) 12VDC SUPPLY WIRE TO THE THERMOSTAT	N / A
B or BLUE	TWO BLUE, ONE (-) 12VDC SUPPLY WIRE TO THE THERMOSTAT AND ONE BLUE WIRE TO CEILING ASSEMBLY / PLENUM	B
Y or YELLOW	ONE YELLOW, COMPRESSOR CONTROL WIRE TO CEILING ASSEMBLY / PLENUM	Y
GH or GREEN	ONE GREEN, HIGH FAN CONTROL WIRE TO CEILING ASSEMBLY / PLENUM	GH
GL or GRAY	ONE GRAY, LOW FAN CONTROL WIRE TO CEILING ASSEMBLY / PLENUM	GL
W or WHITE	ONE WHITE, 12VDC (+) FURNACE CONTROL WIRE FROM THE THERMOSTAT	FURNACE

NOTE: The (W) White wire is not available on COOL ONLY thermostats.

NOTE: THE CONNECTING WIRES TO THE THERMOSTAT ARE PROVIDED BY THE VEHICLE MANUFACTURER OR INSTALLER. THESE O.E.M. OR VENDOR SUPPLIED WIRES MAY NOT BE COLOR CODED AS NOTED IN THE CHART ABOVE. THE GROUND WIRE MUST BE A ZERO “0” RESISTANCE GROUND.

THERMOSTAT LOCATION

Thermostats are very sensitive instruments. For accurate temperature control and comfort the following considerations for thermostat locations should be taken into account:

1. Locate the thermostat on an inside wall about five foot above the floor. Pick a dry area where air circulation is good. The thermostat should be mounted within a reasonable distance from the appliance the thermostat will control. This will assure a more accurate temperature relationship between the thermostat and the appliance the thermostat will control.
2. Do not install the thermostat where there are unusual heating conditions; such as direct sunlight, heat producing appliances (television, radio, wall lamp, etc.); or a furnace or air conditioner supply register.
3. Note: When installing or servicing these thermostats the technician should take all necessary precautions not to short any positive wire to ground. Permanent damage to the thermostat may occur. Make sure all connections are good and tight. Loose connections may cause relay chattering which leads to welded relay contacts on air conditioner printed circuit boards.

II. INTRODUCTION TO RELAYS

In the previous chapter on thermostats we learned the wall thermostat makes necessary connections that provide low voltage power to initiate all of the air conditioning or heating functions. There is one question left unanswered. How do we use this 12VDC power to operate a 115VAC appliance? THE ANSWER IS: We use relays or printed circuit boards with relays located on them.

HOW DO RELAYS FUNCTION

So what is a relay? A relay is defined as an electromagnetic mechanism moved by a small electrical current in a control circuit (12VDC in this case). How does this relay work? As this mechanism moves back and forth in the relay it will open or close a set of contacts capable of carrying high voltage and (115VAC in this case). All of our control circuit relays are normally open and the contacts close as power from the thermostat is applied.

As shown in Figure 1. on the next page, the 115VAC power to the compressor is interrupted by a set of normally open contacts on the relay. In order for these contacts to close 12VDC must be applied by the wall thermostat to the relay coil. When the thermostat switch is placed in the cool position 12VDC(+) travels from the thermostat red wire to the thermostat yellow (Y) wire and then to the relay coil. When the coil is activated an electromagnet inside the relay will pull the contacts closed. The 115VAC will now operate the compressor until the thermostat opens or the system switch is turned to the off position.

Figure 1. shows a very simplified control circuit for compressor operation only. The entire control circuit for the A/C / Heating system would include the rest of the thermostat functions and possibly 2 or 3 more relays. In addition to the compressor relay you would need a separate relay for **Low Fan**, one for **High Fan**, and possibly one for **Heat**, if a heat pump or electric heating element is used. Please refer to the previous lesson or use the chart below for proper wiring from the wall thermostat to each individual relay.

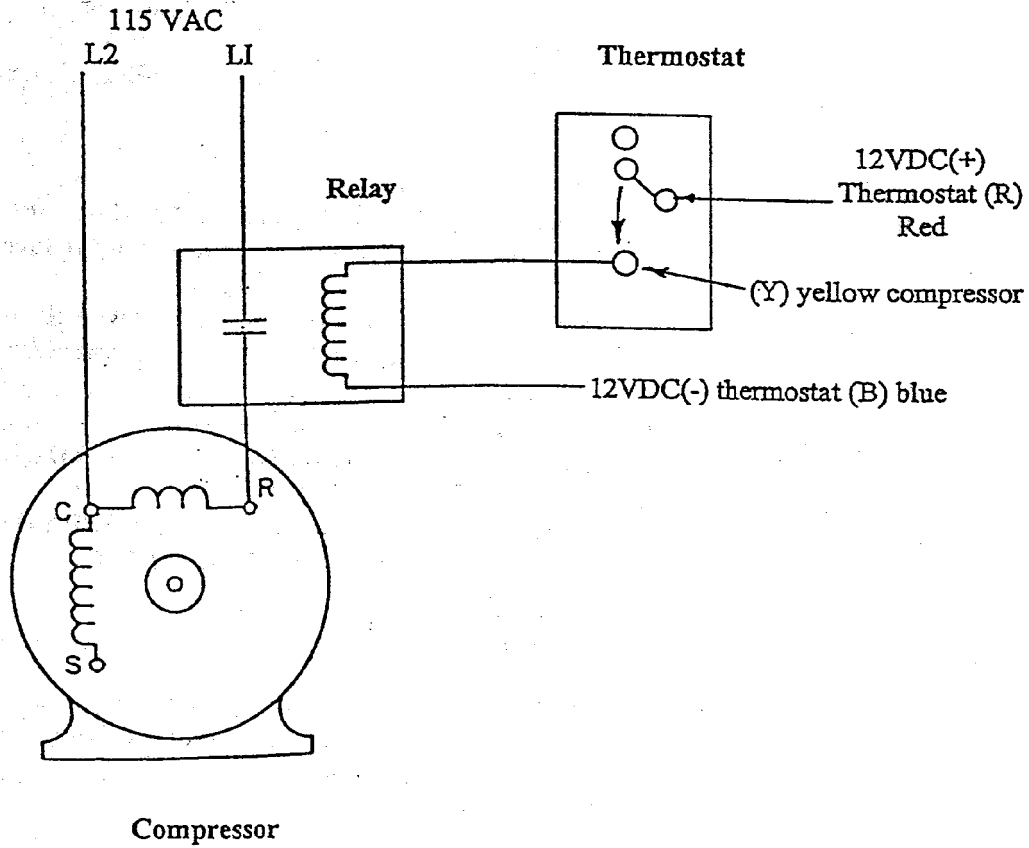

Figure 1

III. CEILING PLENUMS WITH INDIVIDUAL RELAYS

Recreational Vehicle Products built 2 types of ceiling assembly packages which incorporate individual relays for the air conditioner system functions. Line drawing examples of these two ceiling assembly types are shown in figures 2 and 3.

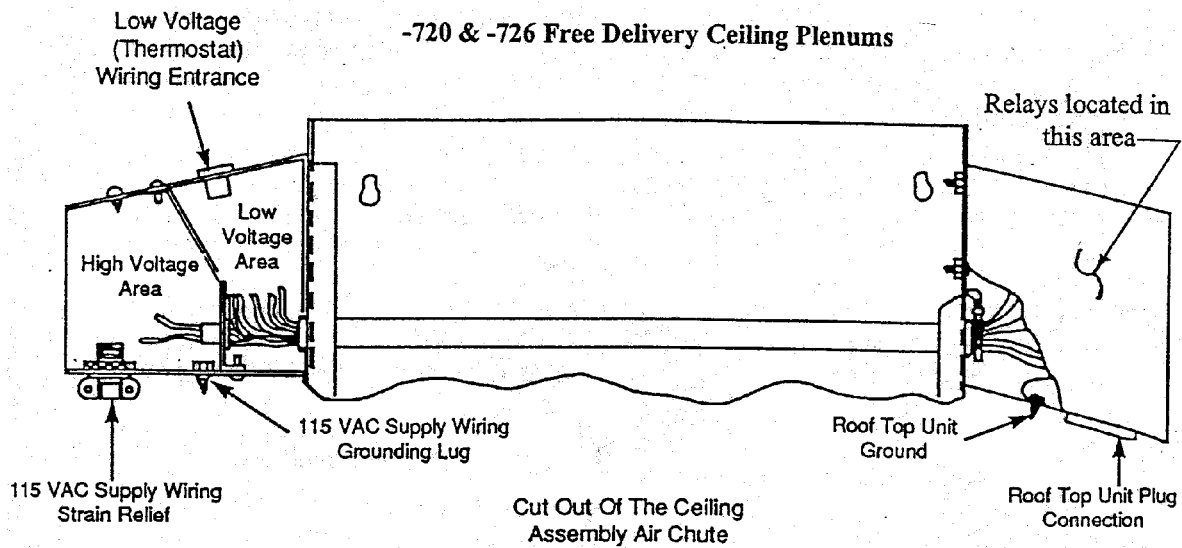

Figure 2.

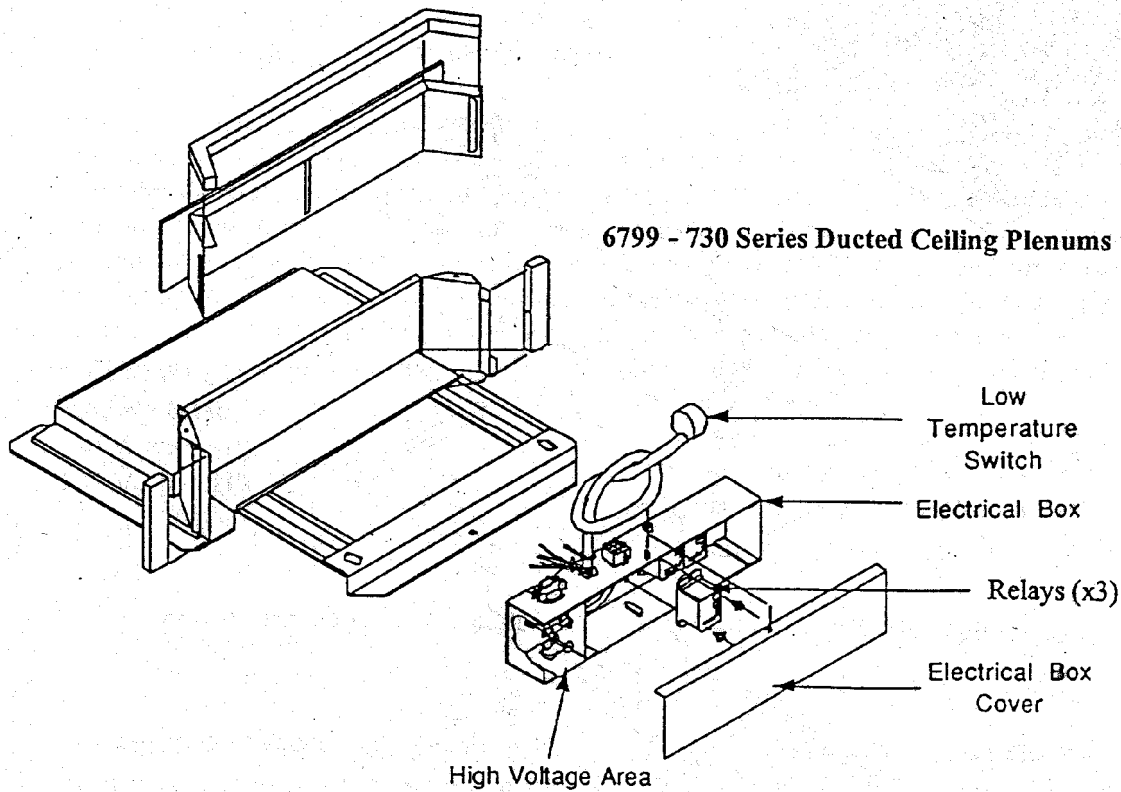

Figure 3

The following charts depict the thermostat control wiring, ceiling assembly wiring destinations, and relay functions for air conditioners with control boxes containing individual relays

6799-720 & -726 SERIES, 7330-720 & 726 SERIES CEILING PLENUMS

THERMOSTAT	CEILING PLENUM WIRE*	UNIT OPERATION
Yellow (Y)	Yellow	Compressor relay
Green (GH)	Green	High Fan relay
Gray (GL)	Gray	Low Fan relay
Blue (B) (12VDC-)	Blue	N/A
White (W)	White	Furnace or Heat Element relay

6799-730 SERIES CEILING PLENUM

THERMOSTAT	CEILING PLENUM WIRE*	UNIT OPERATION
Yellow (Y)	Black	Compressor
Green (GH)	Green	High Fan
Gray (GL)	Gray	Low Fan
Blue (B) (12VDC-)	Blue	N/A
White (W)	White	Furnace or Heat Element relay

* The low voltage wiring connections for these control systems are hard wired by the manufacturer or installer of the unit and they may not all use color coded wire as noted above.

Note: If the heating system includes a gas fired furnace the thermostat white wire will energize the

furnace control circuit, (Usually a time delay relay located at the furnace).

IV. CEILING PLENUMS WITH PRINTED CIRCUIT BOARDS

Most of the 7000 and 8000 series ceiling plenums built since 1992 have had Printed Circuit Boards instead of individual relays. Printed circuit boards are less costly and require less wiring. The Printed Circuit Boards all have relays mounted permanently on them. Even though the boards may look much more complicated they are very easy to troubleshoot. On the following pages you will find some visual aids that will help you trouble shoot these units without removing the thermostat or the air conditioner control box lid.

Recreational Vehicle Products has and is building many ceiling assembly packages which use Printed Circuit Boards to control air conditioner system functions. Just like the individual relays, the Printed Circuit Board must receive a signal from the wall thermostat to operate.

A common ducted ceiling assembly application is shown here in Figure 4.

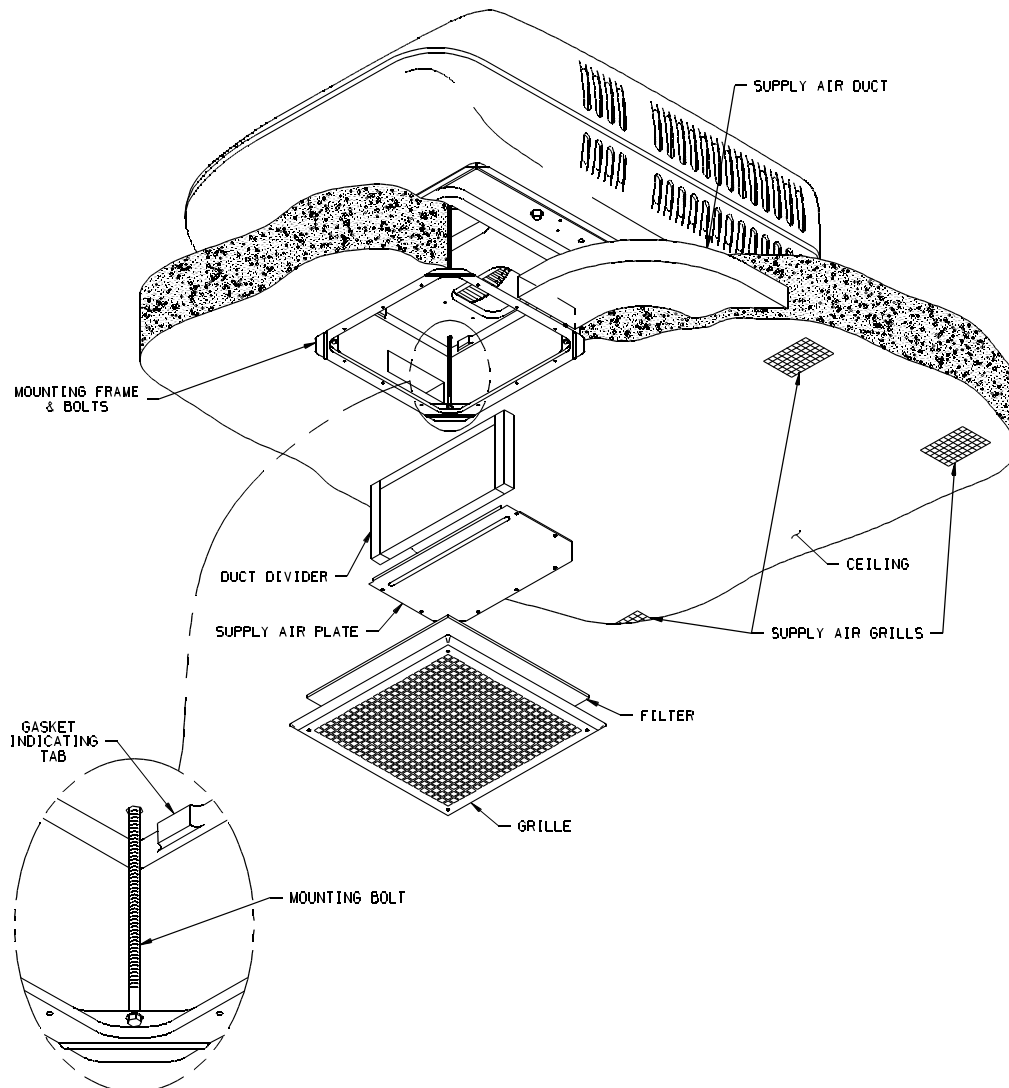

Figure 4

Note: In ducted applications similar to the one found in Figure 4, the Printed Circuit Board / Control Box Assembly is found mounted in the return air opening of the Air Conditioner. In some older applications the Printed Circuit Board / Control Box Assembly will be located in the center of the roof opening just above the return air grille.

Figure 5 shows an exploded view of the Control Box Assembly

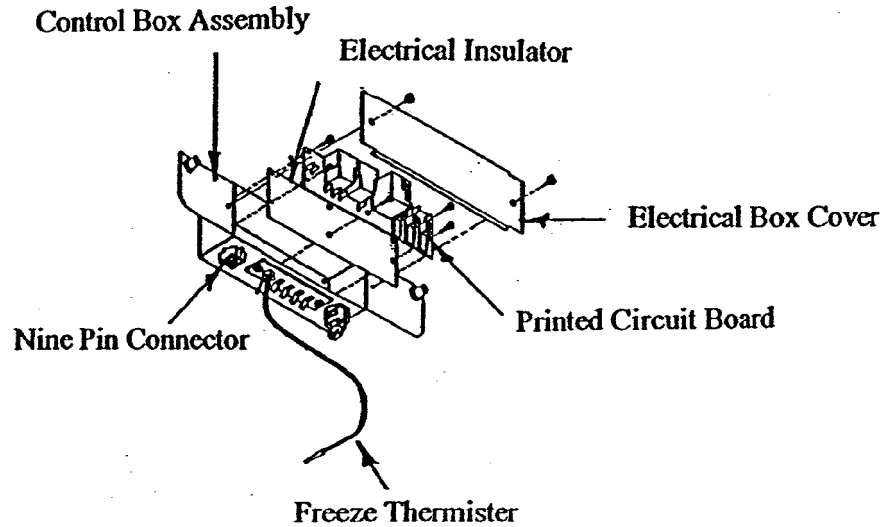

Figure 5

CHECKING THE THERMOSTAT OPERATION

The 12 Volt DC signal from the wall thermostat may be checked at the Low Voltage Terminal Strip (Figure 6) located externally on the ceiling plenum wiring box

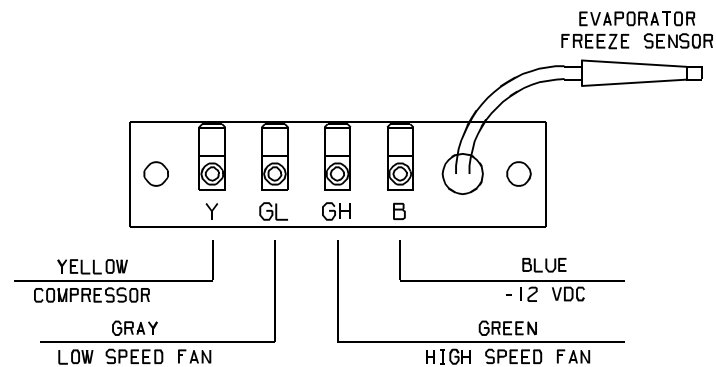

Figure 6. Low Voltage Terminal Strip

Anytime the thermostat is placed in the FAN ONLY position you should be able to read 12VDC between terminals GH and B at the Low Voltage Terminal Strip (see figure 6) .

Anytime the thermostat is placed in the LOW COOL position you should be able to read 12VDC between terminals GL and B for the Low Fan, and between terminals Y and B for compressor operation.

Anytime the thermostat is placed in the HIGH COOL position you should be able to read 12VDC between terminals GH and B for the High Fan, and between terminals Y and B for Compressor operation.

Note: Thermostat operation in the Heating Mode cannot be tested at the Ceiling Assembly Low Voltage Terminal Strip if the thermostat is operating a gas fired furnace.

Note: The wall thermostat will be equipped with an optional Electric Heat / Gas Heat switch if the Recreational Vehicle is equipped with a Heat Pump or with an Electric Heating Element. In this case the Electric Heat Mode may be checked the Low Voltage Terminal Strip. In either case the Low Voltage Terminal Strip will have an additional terminal labeled “W” for electric heating operation. When Electric Heat is chosen at the thermostat you should be able to read 12VDC between terminals W and B. Please note, the “W” terminal is not shown on the Low Voltage Terminal Strip (Figure 6) or in the chart below because it is not tremendously common.

THERMOSTAT	CEILING ASSEMBLY TERMINAL	UNIT OPERATION
Yellow (Y)	(Y)	Compressor
Green (GH)	(GH)	High Fan
Gray (GL)	(GL)	Low Fan
Blue (B) (12VDC-)	(B)	N/A

If you do not find voltage at the Ceiling Assembly Low Voltage Terminal Strip as described above the problem needs to be traced back to the thermostat or the vehicles low voltage wiring.

CHECKING THE PRINTED CIRCUIT BOARD OPERATION

Low voltage MUST be verified at the Low Voltage Terminal Strip as described earlier in this text or as noted in the chart below before preceding to the next step, or checking the Printed Circuit Board.

In order to continue you must **first verify the 115VAC power source** to the Air Conditioner Control Box Assembly. If the 115VAC power source is NOT present, all of the Air Conditioner functions will be dead and power must be restored to continue. 115VAC power must be present to the Circuit Board if any one of the Air Conditioner functions are working.

The operation of the printed circuit board may be checked at the High Voltage 9-Pin Connector (Figure 7) without removing the electric box lid. The chart below shows the 115VAC connections made by the Circuit Board to the High Voltage 9-Pin Connector

THERMOSTAT CONNECTIONS AT THE LOW VOLTAGE TERMINAL STRIP

12VDC at Y and B
12VDC at GH and B
12VDC at GL and B

115VAC CONNECTIONS MADE BETWEEN TERMINALS AT THE 9 PIN CONNECTOR

Terminals # 1 and # 3
Terminals # 5 and # 9
Terminals # 6 and # 9

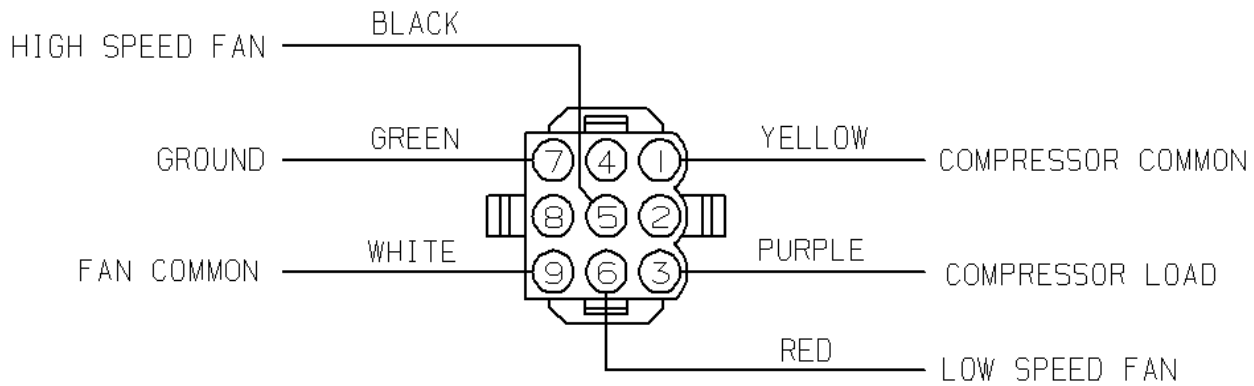

Figure 7. High Voltage 9-Pin Connector

Note: To check voltage at the 9 pin connector plug it may be necessary to unplug the upper unit from the control box

If the Air Conditioner is still not functioning and both 12VDC and 115VAC are present and accountable at their proper locations the problem is located in the upper unit.

If the correct 115VAC connections are NOT made at the 9 pin connector plug after 12VDC power is applied to the Low Voltage Terminal Strip; the problem is in the Printed Circuit Board with one exception as described below.

The low temperature freeze thermistor could open the compressor relay on the Circuit Board if the Air Conditioner Evaporator Coil starts to freeze. If this switch opens you would still have 12VDC at terminals Y and B, but no voltage would be present at terminals 1 and 3 in the High Voltage 9-Pin Connector. The Freeze Thermistor opens if the evaporator coil temperature drops below 32 degrees and closes at 55 degrees. The probe end of this switch should be found pushed into the fins of the evaporator coil and the wires are hooked to the Printed Circuit Board. It is OK to remove the thermistor wire from the Board and jump around these terminals for diagnostic purposes.

If the Air Conditioner compressor is running and NO VOLTAGE is found between terminals Y and B on the Low Voltage Terminal Strip the Printed Circuit Board must be replaced. The compressor relay has evidently welded shut.

In conclusion, you can save a lot of time if you get in the habit of going immediately to the ducted control box assembly for trouble shooting purposes. There in a matter of minutes you can tell if the problem is in the Thermostat, the Printed Circuit Board, or the Upper Unit.

V. DIAGNOSTIC FLOW CHARTS

Note: When working with the following diagnostic flow charts, start at the top left corner and work towards the right or down the page as applicable. Do not skip around or start in middle without performing all prior steps.

DANGER
THE FOLLOWING DIAGNOSTIC TESTING WILL BE DONE ON ENERGIZED
CIRCUITS. ELECTRICAL SHOCK CAN OCCUR IF NOT TESTED PROPERLY.
TESTING TO BE DONE BY QUALIFIED TECHNICIANS ONLY

No High Fan Operation
(Thermostat in the FAN ONLY or HIGH COOL position)

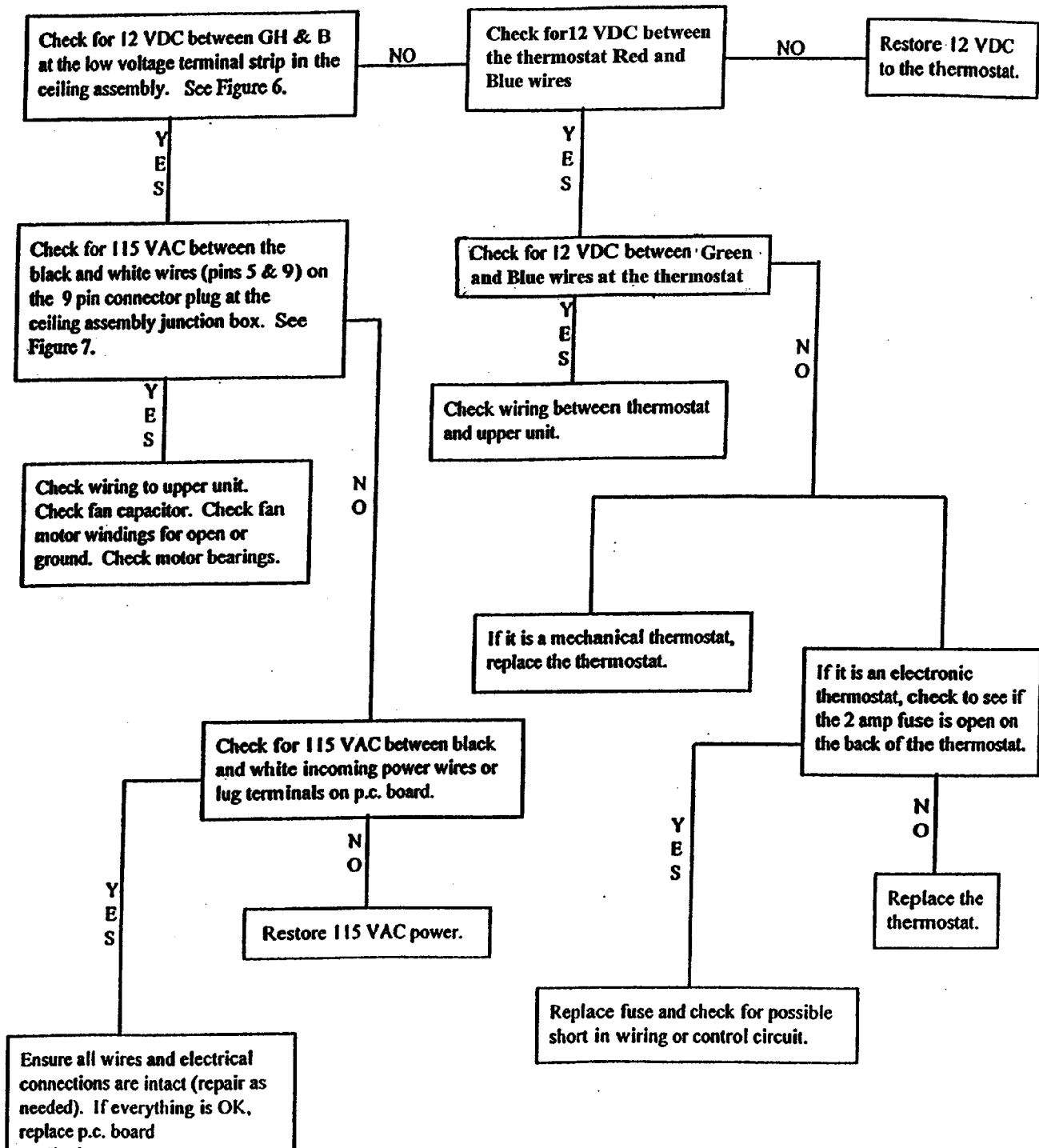

Note: To check voltage at the plug, it may be necessary to unplug the upper unit from the wirebox.

No Low Fan Operation
(Thermostat in the LOW COOL position)

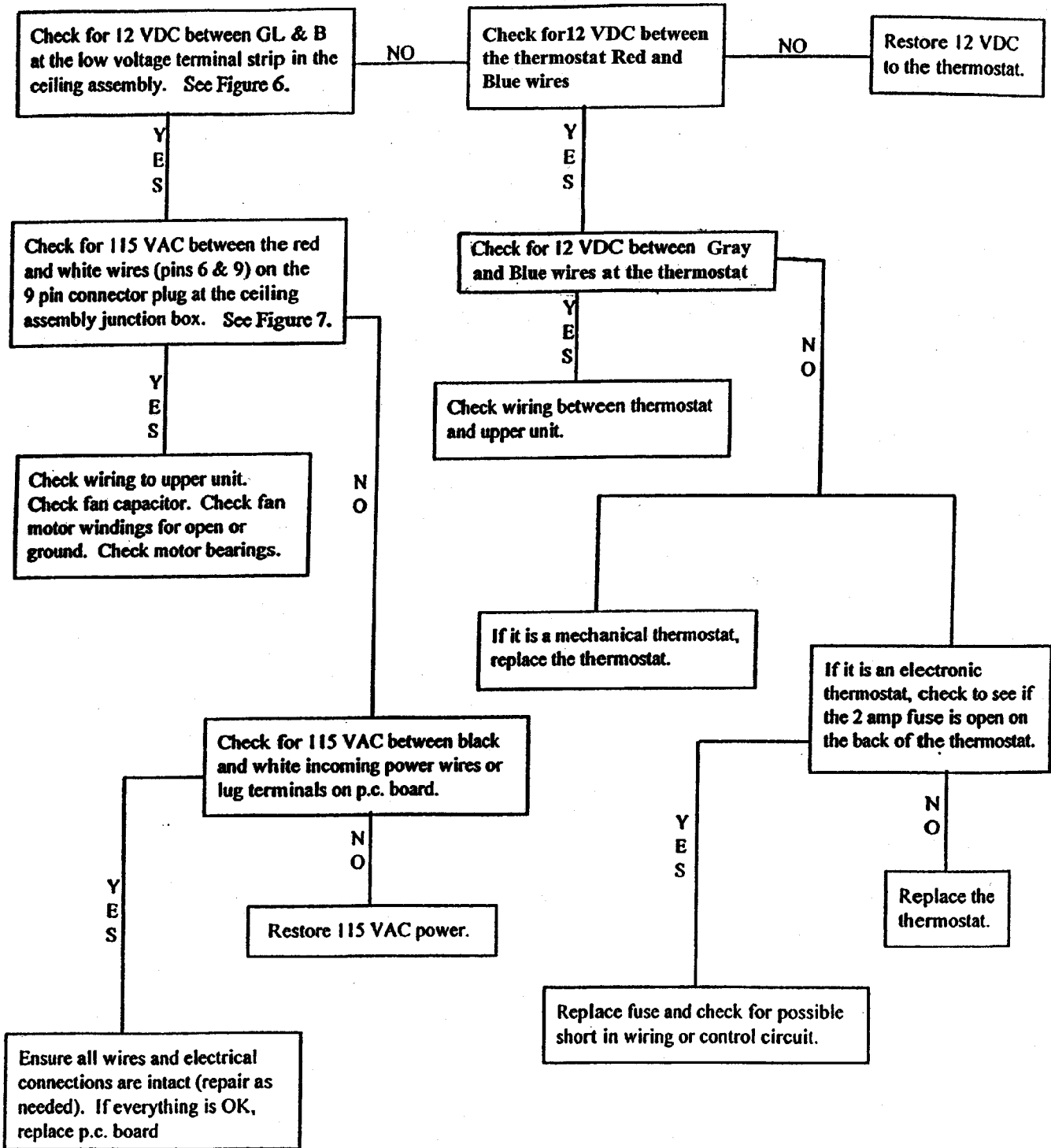

Note: To check voltage at the plug, it may be necessary to unplug the upper unit from the wirebox.

No Furnace Operation
(Thermostat in Heat Position and Temperature Control set above room temperature)

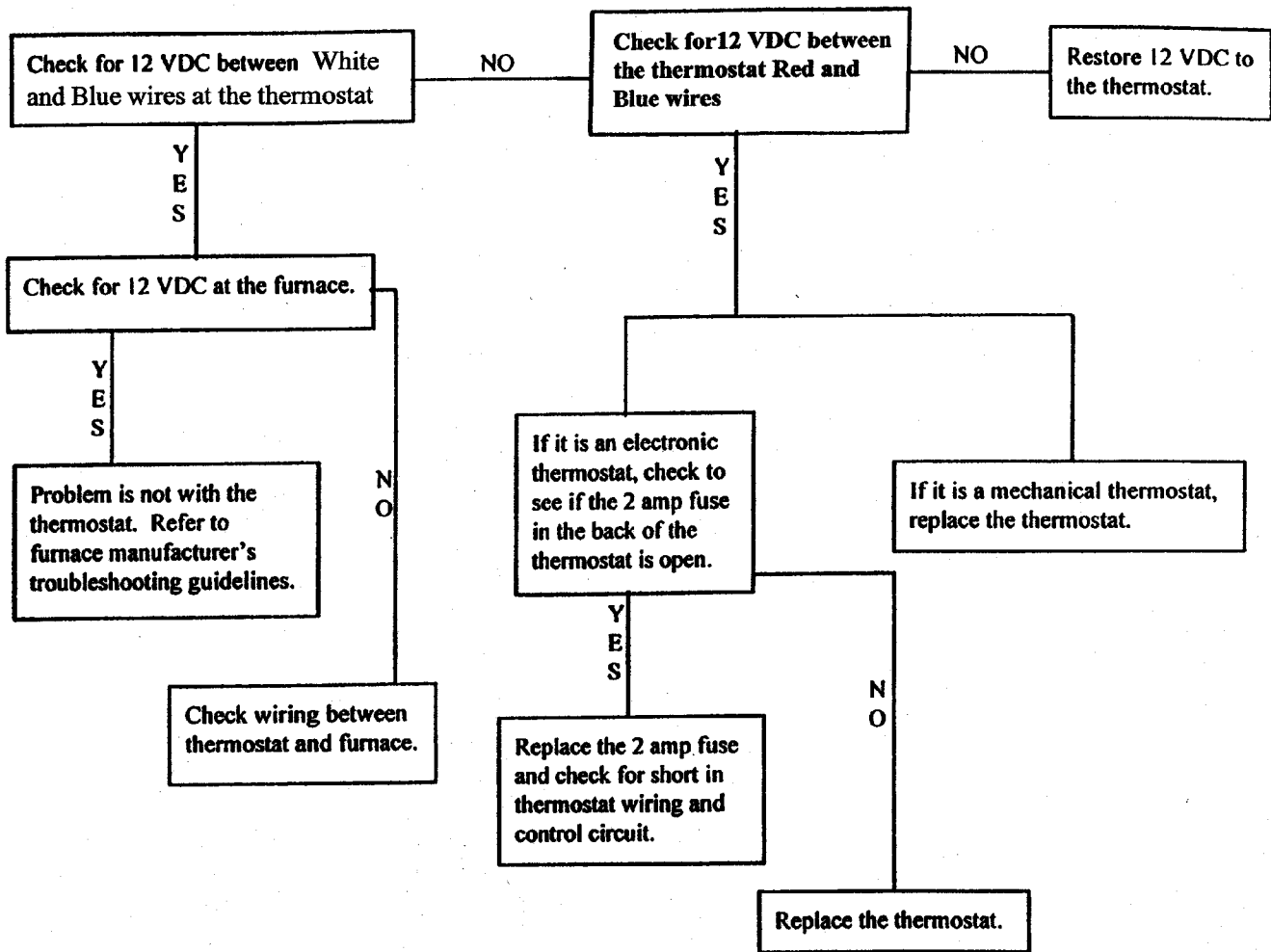

Note: Some furnace manufacturers use operation delays and special cycling features.

IMPORTANT NOTICE:
HEAT ANTICIPATORS (MECHANICAL THERMOSTATS)

1. The heat anticipator setting on the thermostat should match the furnace manufacturer's load on the thermostat.
2. An anticipator setting of a greater number will result in longer furnace run times/fewer cycles per hour. Lower value settings will result in shorter furnace run times/more cycles per hour.
3. The heat anticipator setting is automatic and non adjustable on all electronic thermostats.

No Compressor Operation
(Thermostat in Cool Position and Temperature Control set below room temperature)

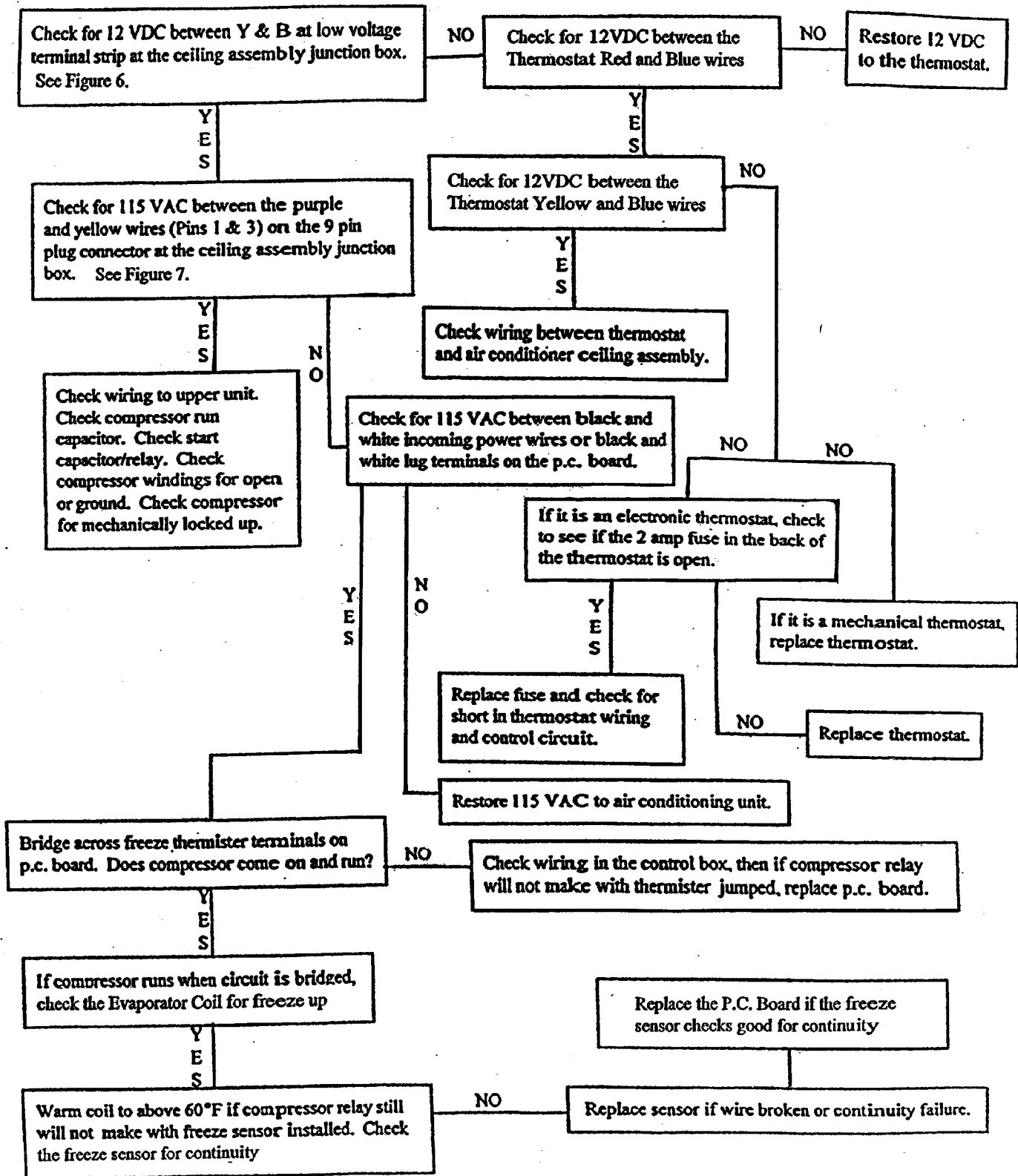

VI. WIRING DIAGRAMS

7330-730 & 8330-733 Series Cool Only Ducted Ceiling Plenums

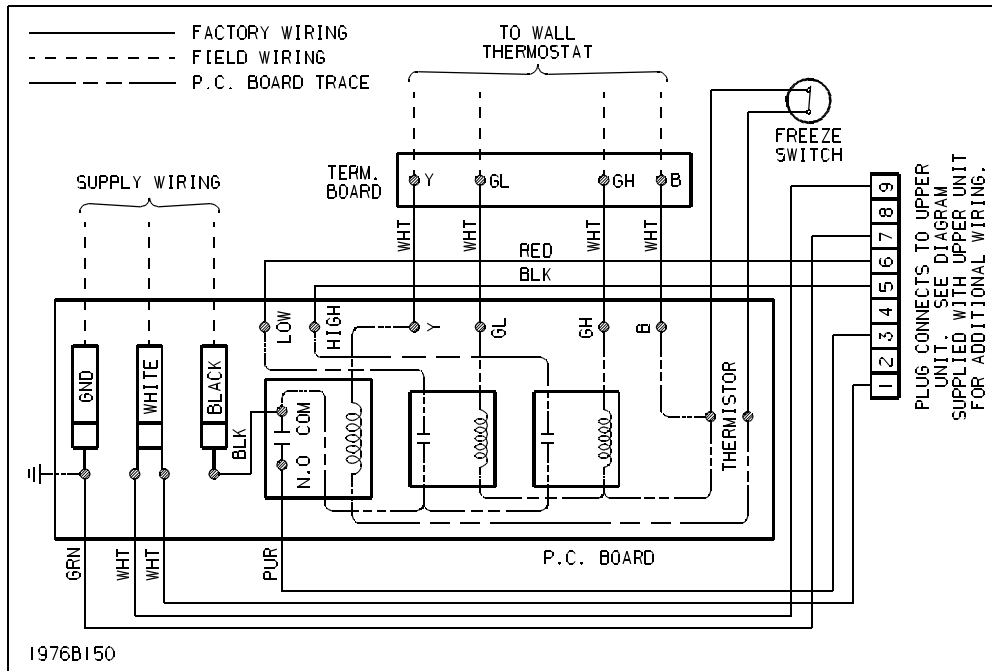

7330-735, 7330-736 & 8330-735 Series Heat/ Cool Ducted Ceiling Plenums

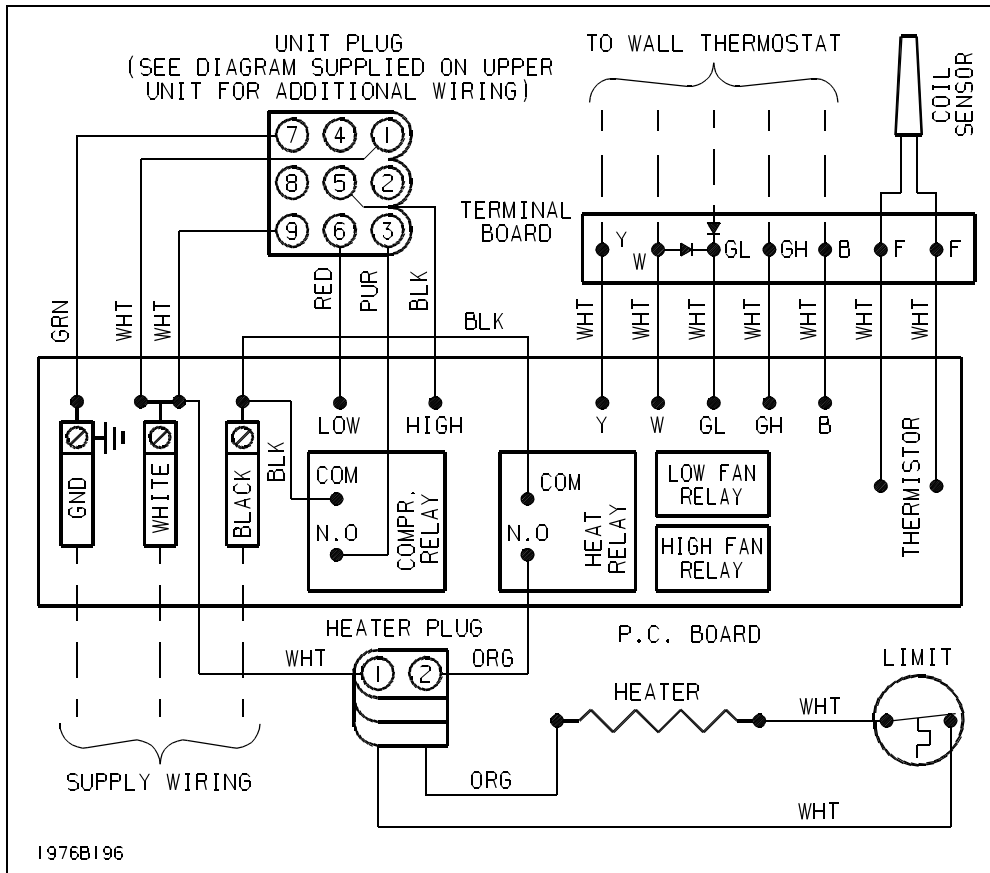

7330-720 & 8330-723 Series Cool Only Remote Free Delivery Ceiling Plenums

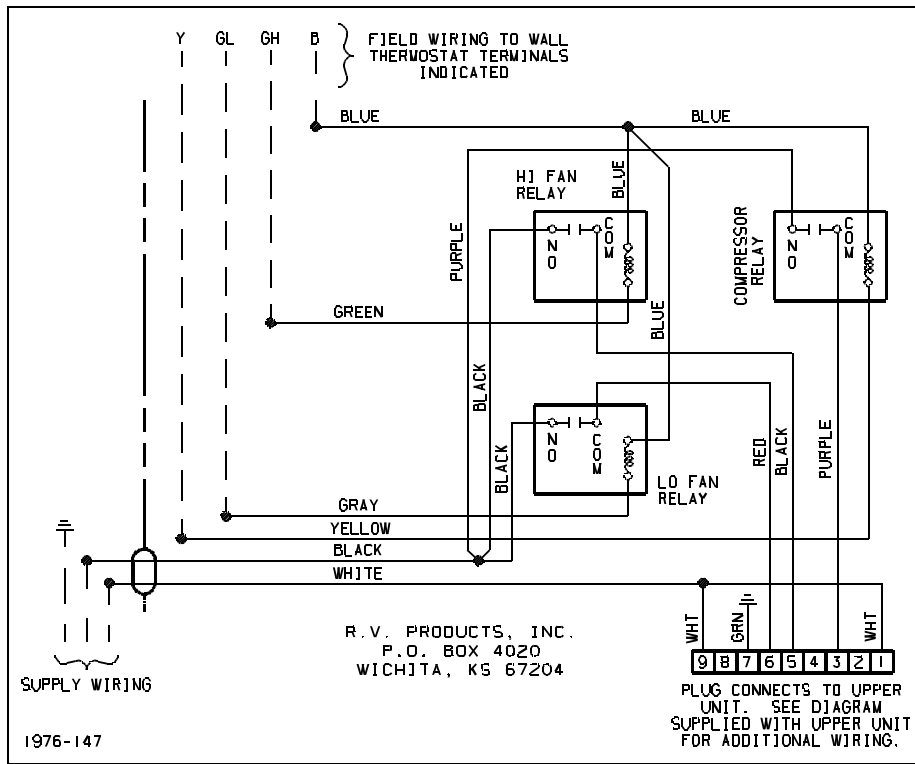

7330-725, 7330-726 & 8330-725 Series Heat/Cool Remote Free Delivery Ceiling Plenums

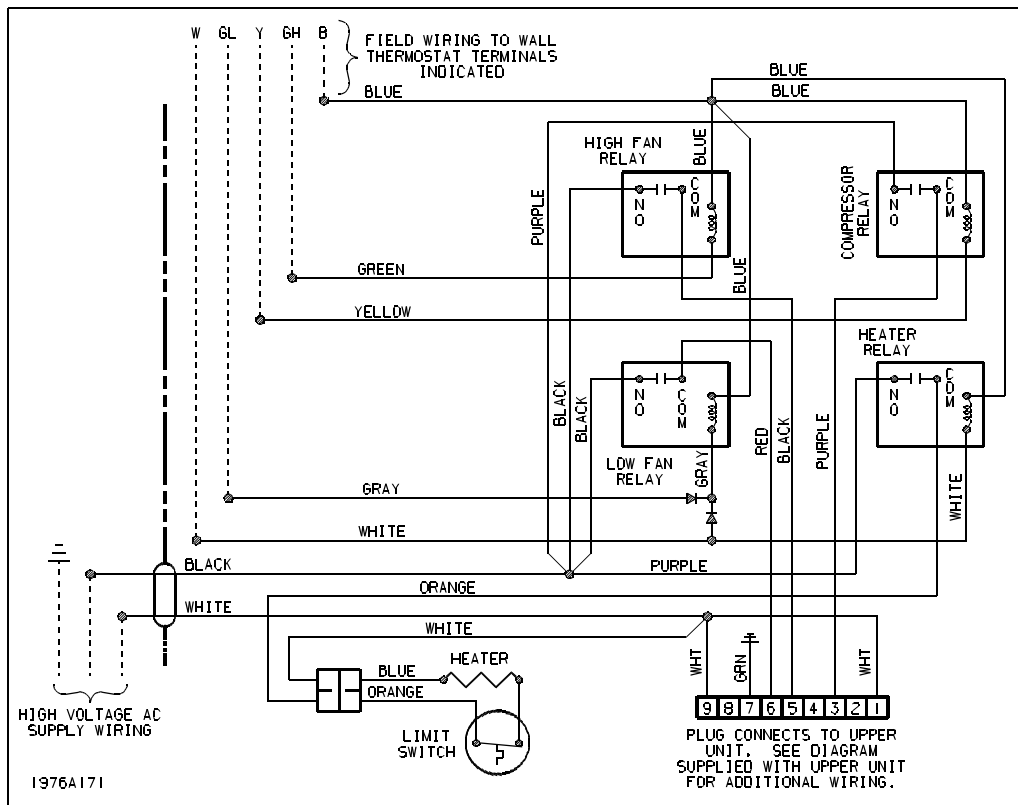



RV Products
A Division of Airxcel, Inc.
P.O. Box 4020
Wichita, KS 67204

1976-376 (4-02)