



OPERATOR'S MANUAL

HWH® HYDRAULIC SPACEMAKER® ROOM EXTENSION SYSTEMS

FEATURING:

Single / Multiple Room Extensions / Generator Slide

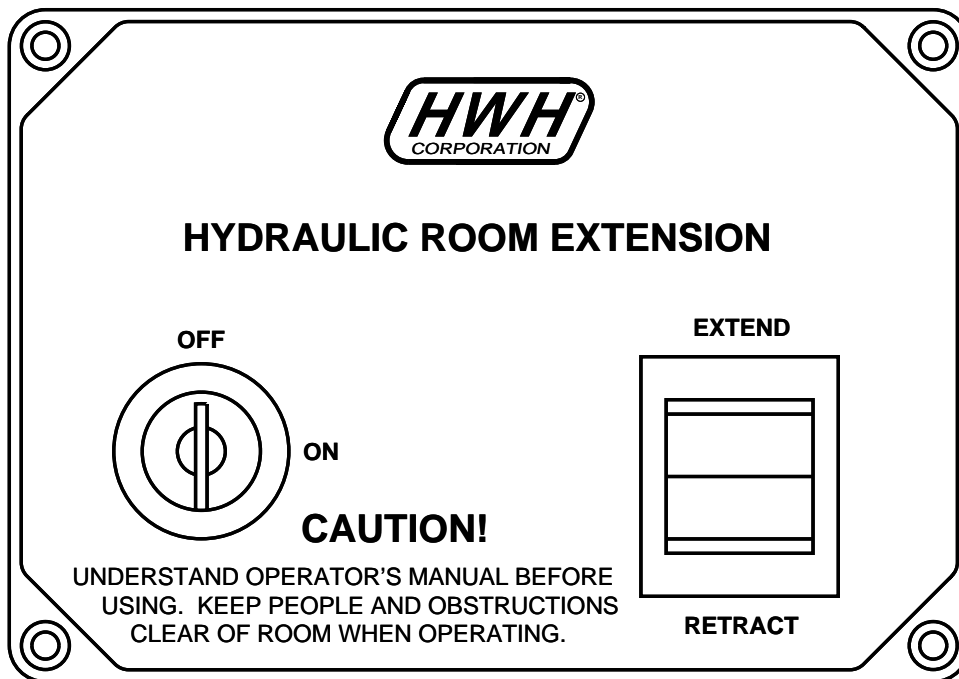

HWH CORPORATION

(On I-80, Exit 267 South)

2096 Moscow Road | Moscow, Iowa 52760

Ph: 800/321-3494 (or) 563/724-3396 | Fax: 563/724-3408

www.hwh.com

OPERATOR'S MANUAL

WARNING !

READ THE ENTIRE OPERATOR'S MANUAL BEFORE OPERATING.

KEEP PEOPLE AND OBSTRUCTIONS CLEAR OF ROOM OR STEP WHEN OPERATING. ANY OBJECT OBSTRUCTING ROOM OR STEP MOVEMENT MAY BE CRUSHED CAUSING INJURY OR DEATH AND VEHICLE DAMAGE.

NEVER PLACE HANDS OR OTHER PARTS OF THE BODY NEAR HYDRAULIC LEAKS. OIL MAY PENETRATE SKIN CAUSING INJURY OR DEATH.

WEAR SAFETY GLASSES WHEN INSPECTING OR SERVICING THE SYSTEM TO PROTECT EYES FROM DIRT, METAL CHIPS, OIL LEAKS, ETC. FOLLOW ALL OTHER APPLICABLE SHOP SAFETY PRACTICES.

HOW TO OBTAIN WARRANTY SERVICE

THIS IS NOT TO BE INTERPRETED AS A STATEMENT OF WARRANTY

HWH CORPORATION strives to maintain the highest level of customer satisfaction. Therefore, if you discover a defect or problem, please do the following:

FIRST: Notify the dealership where you purchased the vehicle or had the leveling system installed. Dealership management people are in the best position to resolve the problem quickly. If the dealer has difficulty solving the problem, he should immediately contact the Customer Service Department, at HWH CORPORATION.

SECOND: If your dealer cannot or will not solve the problem, notify the Customer Service Department:
HWH CORPORATION 2096 Moscow Rd. Moscow IA. 52760
(563) 724-3396 OR (800) 321-3494. Give your name and address, coach manufacturer and model year, date the coach was purchased, or the date of system installation,

description of the problem, and where you can be reached during business hours (8:00 a.m. till 5:00 p.m. c.s.t.). HWH CORPORATION personnel will contact you to determine whether or not your claim is valid. If it is, HWH CORPORATION will authorize repair or replacement of the defective part, either by appointment at the factory or by the authorization of an independent service facility, to be determined by HWH CORPORATION. All warranty repairs must be performed by an independent service facility authorized by HWH CORPORATION, or at the HWH CORPORATION factory, unless prior written approval has been obtained from proper HWH CORPORATION personnel.

CONTROL IDENTIFICATION

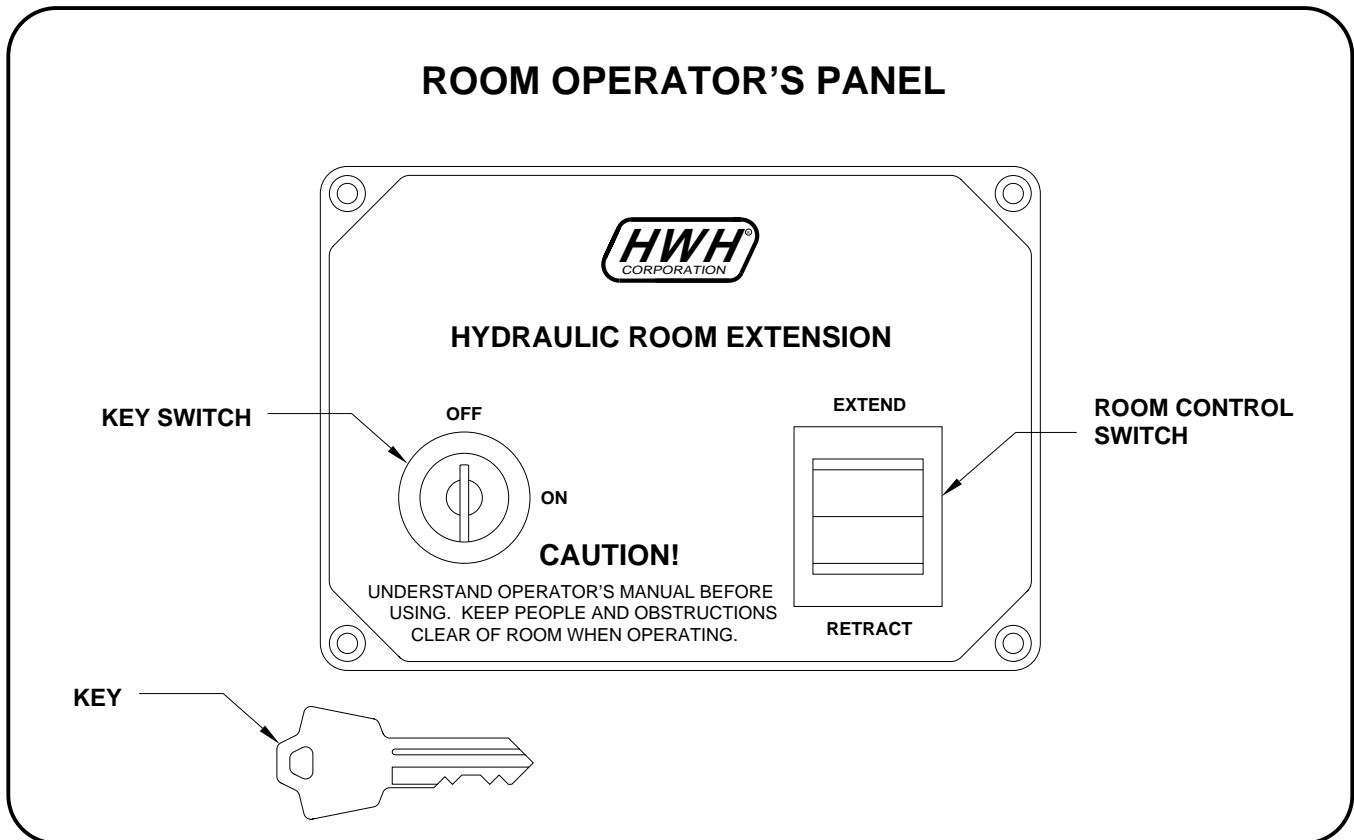

CONTROL FUNCTIONS

KEY SWITCH: The KEY SWITCH controls power to the ROOM CONTROL SWITCH. When the KEY SWITCH is in the "ON" POSITION the room can be operated, and the key cannot be removed. When the KEY SWITCH is in the "OFF" position the room cannot be operated, and the key can be removed.

ROOM CONTROL SWITCH: The ROOM CONTROL SWITCH is a two position momentary switch. Pressing the switch in the EXTEND POSITION will extend the room. Pressing the switch in the RETRACT POSITION will retract the room. Releasing the ROOM CONTROL SWITCH will halt the operation of the room. The panel may be equipped with two rocker switches for controlling multiple rooms.

OEM PROVIDED ROOM SELECTOR SWITCH (IF APPLICABLE)

ROOM SELECTOR SWITCH: This switch (not shown) is OEM provided. Refer to OEM operator instructions.

CONTROL IDENTIFICATION

PUMP RUN TIME

PUMP RUN TIME

Pump motors used with HWH leveling systems and room extension systems come in 3 different diameters; 3", 3.7" and 4.5". Contact the vehicle manufacturer or HWH for help with identifying the motor size. **It is important that any time the pump runs for more than four minutes with a 3" motor; or six minutes with a 3.7" or 4.5" motor that the motor is allowed to cool for thirty minutes before continuing. Continuous operation of the pump motor without allowing the motor to cool can damage the motor.** For cold weather information see "COLD WEATHER OPERATIONS" below.

The HWH systems with a computer processor monitor the pump run time and will turn the pump off if the run time exceeds a specified time. This time can vary with different systems. Due to available electronics or system design, the pump run time programs will also vary. Leveling systems and room extensions that are not controlled by a system processor have no pump run time protection. **DO NOT run the pump more than four or six minutes without allowing the pump motor to cool for thirty minutes.**

SYSTEM VARIATIONS FOR PUMP RUN TIME

Some systems with rooms run the rooms separate from the system processor. These systems do not monitor pump run time when operating the rooms. **DO NOT run the pump more than four or six minutes without allowing the pump motor to cool for thirty minutes.**

Some systems can be turned back on immediately after the processor turns the pump off. **DO NOT turn the system back on or run the pump without allowing the pump motor to cool for thirty minutes.**

When operating some leveling systems manually or operating the room extensions, the pump will turn off and back on while pushing the control button when the pump run time has been exceeded. **DO NOT continue without allowing the pump motor to cool for thirty minutes.**

With some systems, when the processor has turned the pump off because the run time has been exceeded, power to the HWH system must be turned off and back on before the system will operate. With motorized vehicles, turn the ignition off and back on. With non-motorized vehicles, turn the master power switch for the HWH system off and back on. **DO NOT continue without allowing the pump motor to cool for thirty minutes.**

Some HWH systems are equipped with a lighted reset switch. If the processor turns the pump off because the run time has been exceeded, the light in the reset switch will turn on. The system will not operate until the reset switch is pushed.

DO NOT continue without allowing the pump motor to cool for thirty minutes.

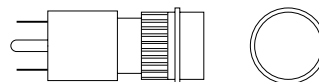

LIGHTED RESET SWITCH

No matter what HWH system is on the vehicle, the pump should not be ran for more than four minutes (3" motors) or six minutes (3.7" or 4.5" motors) without allowing the pump motor to cool for thirty minutes. Continuous operation of the pump motor without allowing the motor to cool can damage the pump motor.

Contact HWH corporation to get specific information about the system in this vehicle.

COLD WEATHER OPERATIONS

HWH leveling and room extension systems are designed to function in cold weather down to 0 degrees Fahrenheit. Below freezing (32 degrees Fahrenheit) the jacks or rooms will operate slower than usual.

For operation in temperatures dropping below -20 degrees Fahrenheit, it is necessary that the system is equipped with oil designed for extreme cold weather application such as a synthetic oil. (Contact HWH for recommendations.)

DO NOT run the pump motor continuously. It is important that any time the pump runs for more than four minutes with a 3" motor; or six minutes with a 3.7" or 4.5" motor that the motor is allowed to cool for thirty minutes before continuing. Continuous operation of the pump motor without allowing the motor to cool can damage the motor. Continuous operation of the pump with slow moving jacks or rooms in cold weather, without allowing the pump motor to cool will cause the pump motor to burn up and damage the pump assembly.

OPERATING PROCEDURES

IMPORTANT: This manual covers different mechanism styles and arrangements. If a room is not an HWH mechanism, refer to the correct operator's manual for operating instructions. This manual also covers rooms and slides on motorized or non-motorized vehicles. The operating instructions contained in this manual covers the most common situations. Non-motorized vehicles will not depend on an ignition switch or park brake, but there may be a master power switch for the system.

NOTE: If the vehicle is equipped with an HWH 225 series joystick leveling system, the on light on the leveling system panel MAY have to be on to operate a room extension.

NOTE: Some rooms may be equipped with travel clamps/locks that are NOT supplied by HWH. Refer to the vehicle or clamp/lock manufacturer for correct operating instructions.

GENERAL INSTRUCTIONS

Maintain adequate clearance in all directions for vehicle, room extensions, awnings, doors, steps, etc. Vehicle may move in any direction due to jacks extending or retracting, settling of the jacks or the vehicle, equipment malfunction, etc..

PREPARATION FOR TRAVEL

Any room extension or generator slide should be fully retracted before traveling.

CAUTION: THE VEHICLE SHOULD NOT BE MOVED IF ONE OR MORE ROOMS OR THE GENERATOR SLIDE ARE EXTENDED.

If the rooms cannot be retracted according to the ROOM RETRACT Section, retract the rooms according to the MANUAL ROOM RETRACTION Section. The system should then be checked.

OPERATING PROCEDURES

ROOM EXTEND PROCEDURE FOR ROOMS WITHOUT TRAVEL CLAMPS

WARNING: OPERATING A ROOM WITH ANY ROOM LOCKING, CLAMPING OR MANUAL RETRACTING DEVICES ATTACHED OR ENGAGED CAN CAUSE PERSONAL INJURY AND VEHICLE DAMAGE. IT IS THE OPERATOR'S RESPONSIBILITY TO ENSURE THAT ALL ROOM LOCKING, CLAMPING OR MANUAL RETRACTING DEVICES ARE DETACHED OR DISENGAGED BEFORE OPERATING THE ROOM.

NOTE: It is recommended to complete any applicable Leveling Procedure before operating room extensions. It is recommended to retract room extensions before retracting a leveling system.

1. The park brake must be set for motorized vehicles. The room will not operate if the park brake is not set.
2. Follow applicable LEVELING AND STABILIZING PROCEDURES.
3. Unlock all room-locking devices to include travel clamps/locks supplied by manufacturers other than HWH.

NOTE: If the MANUAL RETRACT WINCH is attached to the room remove it before extending the room.

WARNING: KEEP PEOPLE AND OBSTRUCTIONS CLEAR OF ROOM WHEN OPERATING.

NOTE: Make sure there is adequate clearance to fully extend the room.

4. Turn the ignition switch to ACCESSORY or turn a MASTER POWER SWITCH on, if applicable.
5. Turn the room control panel KEY SWITCH to the "ON" position.

6. To extend the room, press and hold the ROOM CONTROL SWITCH in the "EXTEND" position until the room is fully extended.

IMPORTANT: If the room extension is a level out room, hold the room control switch to the extend position until the room is fully extended and has dropped to the completely lowered position.

NOTE: Hold the switch to "EXTEND" three or four seconds after the room is fully extended. This assures proper pressurization of the cylinders. **During normal operation of the room, do not reverse direction of the room until the room is fully extended. If necessary, the direction of the room may be reversed, but watch for binding of the room. If the direction of the room has been reversed, DO NOT re-extend the room until the room has been fully retracted.**

IMPORTANT: Do not hold the ROOM CONTROL SWITCH in the "EXTEND" position for more than ten seconds after the room is fully extended (and down if applicable) or stops moving. **If either side of the room stops moving, release the room control switch immediately. DO NOT force the room. DO NOT reverse direction of the room, contact HWH Customer Service for assistance 1-800-321-3494.**

NOTE: Releasing the ROOM CONTROL SWITCH will halt the operation of the room.

7. Turn the room control panel KEY SWITCH to the "OFF" position.
8. Turn off the ignition switch, if applicable.

IMPORTANT: Do not use a room extension support when the vehicle is supported by the leveling system.

OPERATING PROCEDURES

ROOM RETRACT PROCEDURE FOR ROOMS WITHOUT TRAVEL CLAMPS

WARNING: KEEP PEOPLE AND OBSTRUCTIONS CLEAR OF ROOM WHEN OPERATING.

NOTE: It is recommended to retract room extensions before retracting a leveling system.

1. The park brake must be set, if applicable. The room will not operate if the park brake is not set.
2. Turn the ignition switch to ACCESSORY or turn a MASTER POWER SWITCH on, if applicable.
3. Turn the room control panel KEY SWITCH to the "ON" position.
4. To retract the room press and hold the ROOM CONTROL SWITCH in the "RETRACT" position until the room is fully retracted.

Important: if the room extension is a level-out room, the room must raise completely before it will retract. If the room will not raise, do not force the room. Refer to the MANUAL ROOM LIFT PROCEDURES page.

NOTE: Hold the switch to "RETRACT" three or four seconds after the room is fully retracted. This assures proper pressurization of the cylinders. **During normal operation of the room, do not reverse direction of the room until the room is fully retracted. If necessary, the direction of the room may be reversed, but watch for binding of the room. If the direction of the room has been reversed, DO NOT retract the room until the room has been fully extended.**

IMPORTANT: Do not hold the ROOM CONTROL SWITCH in the "RETRACT" position for more than ten seconds after the room is fully retracted or stops moving.

If either side of the room stops moving, release the room control switch immediately. DO NOT force the room. DO NOT reverse direction of the room, contact HWH Customer Service for assistance 1-800-321-3494.

NOTE: Releasing the ROOM CONTROL SWITCH will halt the operation of the room.

5. Turn the room control panel KEY SWITCH to the "OFF" position.
6. Turn the ignition switch off, if applicable.
7. If the room will not retract see the MANUAL ROOM RETRACT PROCEDURE.

IMPORTANT: Room-locking devices should be locked while traveling.

OPERATING PROCEDURES

GENERATOR SLIDE EXTEND PROCEDURE

WARNING: KEEP PEOPLE AND OBSTRUCTIONS CLEAR OF SLIDE WHEN OPERATING.

NOTE: Make sure there is adequate clearance to fully extend the slide.

1. THE PARK BRAKE MUST BE SET FOR THE SLIDE TO OPERATE.

2. To extend the slide, press and hold the GENERATOR SLIDE CONTROL SWITCH in the "EXTEND" position. When the slide is fully extended, release the GENERATOR SLIDE CONTROL SWITCH.

IMPORTANT: Do not hold the GENERATOR SLIDE CONTROL SWITCH in the "EXTEND" position for more than ten seconds after the slide is fully extended or stops moving. **DO NOT FORCE THE SLIDE.**

NOTE: Releasing the GENERATOR SLIDE CONTROL SWITCH will halt the operation of the slide.

GENERATOR SLIDE RETRACT PROCEDURE

1. THE PARK BRAKE MUST BE SET FOR THE SLIDE TO OPERATE.

2. To retract the slide, press and hold the GENERATOR SLIDE CONTROL SWITCH in the "RETRACT" position. When the slide is fully retracted, release the GENERATOR SLIDE CONTROL SWITCH.

IMPORTANT: Do not hold the GENERATOR SLIDE CONTROL SWITCH in the "RETRACT" position for more than ten seconds after the slide is fully retracted or stops moving. **DO NOT FORCE THE SLIDE.**

NOTE: Releasing the GENERATOR SLIDE CONTROL SWITCH will halt the operation of the slide.

3. If the slide will not retract see the MANUAL SLIDE RETRACT PROCEDURE.

MANUAL ROOM AND GENERATOR SLIDE RETRACT PROCEDURE

(USE ONLY WHEN THE ROOM WILL NOT RETRACT WITH THE ROOM CONTROL SWITCH)

OVERVIEW

The room can be retracted manually if a hydraulic or electric failure prevents the room from being retracted using the CONTROL SWITCH. For normal retract sequence see the ROOM SLIDE RETRACT PROCEDURES. Refer to the vehicle manufacturer for storage location of the retract device and information for connecting the device to the room.

IMPORTANT: If the vehicle is not equipped with a winch, DO NOT use other pulling devices to retract the room. Follow steps 2 and 3 and try pushing the room in. Contact the vehicle manufacturer or HWH Customer Service at 1-800-321-3494 or 563-724-3396 for assistance.

WARNING: A MANUAL RETRACT WINCH PROVIDED BY HWH IS EQUIPPED FOR MANUALLY RETRACTING THE ROOM ONLY. IT IS NOT TO BE USED FOR LIFTING OR ANY OTHER APPLICATION. HIGH FORCES ARE CREATED WHEN USING A WINCH, CREATING POTENTIAL SAFETY HAZARDS. FAILURE TO FOLLOW ALL WARNINGS AND INSTRUCTIONS MAY CAUSE FAILURE OF THE MANUAL RETRACT WINCH OR CONNECTIONS RESULTING IN DAMAGE OR PERSONAL INJURY. MAINTAIN A FIRM GRIP ON THE WINCH HANDLE AT ALL TIMES. NEVER RELEASE THE HANDLE WHEN RATCHET LEVER IS IN THE OFF POSITION AND THE WINCH IS LOADED. THE WINCH HANDLE COULD SPIN VIOLENTLY AND CAUSE PERSONAL INJURY. CHECK THE WINCH AND STRAPS FOR DAMAGE OR WEAR, AND CHECK FOR PROPER RATCHET OPERATION ON EACH USE OF THE WINCH. DO NOT USE IF DAMAGED OR WORN.

1. Retract jacks following the LEVELING SYSTEM RETRACT PROCEDURE.

NOTE : When manually retracting the room, it is recommended the jacks are retracted before retracting the room.

2. Locate the HYDRAULIC PUMP and/or MANIFOLD unit. Some systems may have a remote manifold.

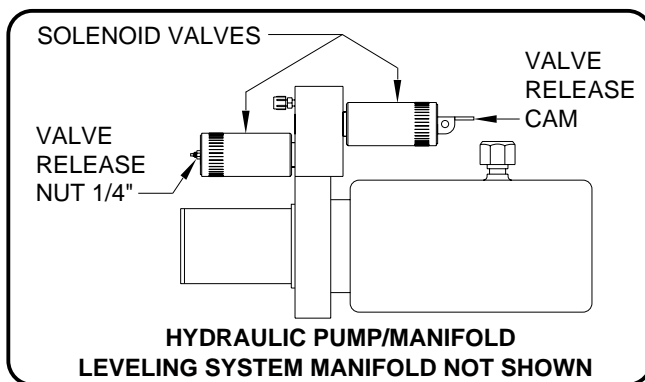

3. Open Nut Style Solenoid Valves by slowly turning the valve release nut counter clockwise using a 1/4" nut driver.

IMPORTANT: Only open the valves enough to retract the room. DO NOT turn the release nuts more than 4 and 1/2 turns. Turning the nuts more could damage the valves.

Open Cam Style Solenoid Valves by following the instructions located on the last page of this manual MP84.9999.

NOTE: The room may move slightly as the SOLENOID VALVES are opened and internal pressure is released.

4. Locate the MANUAL RETRACT DEVICE and connect it to the room according to the vehicle manufacturer's instructions. To extend a WINCH STRAP firmly grasp WINCH HANDLE, place RATCHET LEVER in its OFF position, and slowly rotate the WINCH HANDLE counter clockwise, keeping a firm grip on the handle. When enough WINCH STRAP is extended, place the RATCHET LEVER in its ON position and slowly rotate the WINCH HANDLE clockwise until the RATCHET LEVER locks.

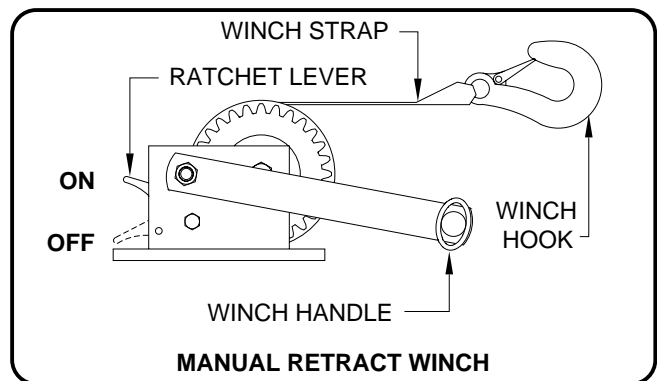

5. Slowly winch the room in by turning the WINCH HANDLE clockwise. The RATCHET LEVER should produce a loud, sharp, clicking noise.

NOTE: Winching the room in quickly will raise pressure in the hydraulic fluid and make winching more difficult.

WARNING: OPERATE THE MANUAL RETRACT WINCH BY HAND POWER ONLY. IF THE WINCH CANNOT BE CRANKED EASILY WITH ONE HAND IT IS PROBABLY OVERLOADED. IF WINCHING BECOMES TO DIFFICULT STOP AND CHECK FOR OBSTRUCTIONS/RESTRICTIONS ON THE ROOM AND ROOM EXTENSION MECHANISM.

6. When the room is fully retracted, engage the room locking devices. Leave the retract winch engaged and the solenoid valves open.

WARNING: THE ROOM EXTENSION SOLENOID VALVE RELEASE MUST BE IN THE OPEN POSITION WHEN THE MANUAL RETRACT WINCH IS ENGAGED.

7. The system should be repaired before using again.

NOTE: After repairs are made, when closing the VALVE RELEASE NUTS, do not over tighten the nuts.

OPERATING PROCEDURES

"STRAIGHT OUT" OR "LEVEL-OUT" (ANGLE MOUNT)

ROOM EXTENSION MECHANISM - MANUAL ROOM RETRACTION

IMPORTANT: READ THESE INSTRUCTIONS THOROUGHLY BEFORE ATTEMPTING TO USE THE MANUAL RETRACT BOLTS TO RETRACT THE ROOM.

1. Determine which extend and retract solenoid valves are assigned to the room. Manually open valve release nuts for the extend and retract solenoid valves by turning the 1/4" release nuts counter clockwise 4 and 1/2 turns. Turning the nuts more could damage the valves. **If equipped with release cams, move the cams to the open position. If necessary, open all valves on the pump/manifold arrangement. There are 4 valves for the leveling system (if applicable) and 2 valves for each HWH room extension.**

NOTE: The breather cap dip stick is also a 1/4" nut driver.

2. Gain access to the 13/16" Manual Retraction Bolts (one on each mechanism), refer to vehicle manufacturer instructions.

3. Remove the Thumb Screws (one on each mechanism) completely by turning them counterclockwise.

4. Using wrench provided, a personal wrench or a tire iron with a 13/16" or 21mm opening rotate either mechanism's Manual Retraction Bolt clockwise 6 complete turns.

5. Move to the second room extension mechanism, rotate the Manual Retraction Bolt clockwise 12 complete turns.

6. Return to the first room extension mechanism and rotate the Manual Retraction Bolt clockwise 12 complete turns.

7. Repeat steps 4 and 5 alternating from mechanism to mechanism rotating each Manual Retraction Bolt 12 complete turns until room is sealed. **(DO NOT EXCEED 15 FT.LBS. FORCING THE MANUAL RETRACT BOLT MAY DAMAGE THE MANUAL RETRACT MECHANISM.) Make sure the room does not bind.**

8. Replace both Thumb Screws. Leave the manual valve releases open.

IMPORTANT: If at any stage something is not understood or if the room begins to bind DO NOT force the room, contact HWH Customer Service for assistance 1-800-321-3494.

IMPORTANT: DO NOT EXTEND THE ROOM UNTIL THE STEPS BELOW HAVE BEEN COMPLETED!

1. Gain access to the 13/16" Manual Retraction Bolts (one on each mechanism), refer to vehicle manufacturer instructions.

2. Remove the Thumb Screws (one on each mechanism) completely by turning them counterclockwise.

3. If needed, using wrench provided, a personal wrench or a tire iron with a 13/16" or 21mm opening rotate either mechanism's Manual Retraction Bolt counterclockwise until resistance is met.

4. Move to the second room extension mechanism and repeat step 3.

5. Replace both Thumb Screws.

6. Close both manual valve releases assigned to the room. Turn valve release nuts clockwise until snug. **DO NOT over tighten. DO NOT move valve release cams in the wrong direction.**

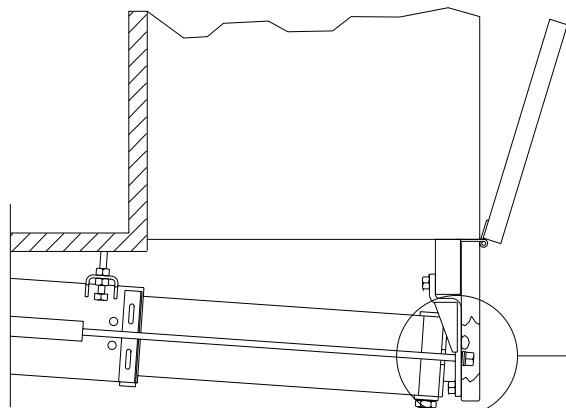
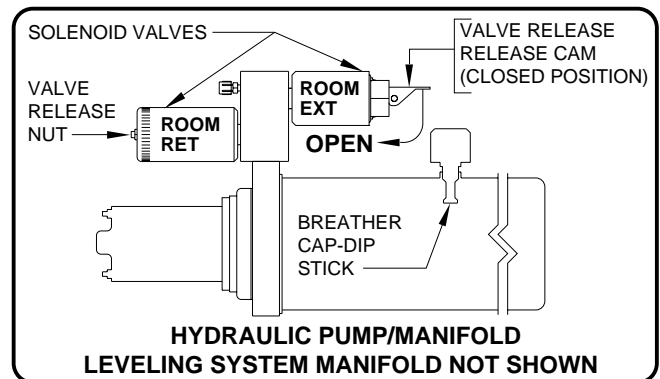

Actual Mounting May Differ

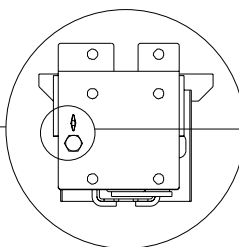

Thumb Screw

Manual Retraction Bolt

**MP34.9551
10OCT13**

OPERATING PROCEDURES

"LEVEL-OUT" ROOM EXTENSION MECHANISM

MANUAL ROOM RETRACTION PROCEDURES

1. Determine which extend and retract solenoid valves are assigned to the room. Manually open the valve release nuts for the extend and retract solenoid valves by turning the 1/4" release nuts counter clockwise 4 and 1/2 turns. Turning the nuts more could damage the valves.

NOTE: The breather cap dip stick is also a 1/4" nut driver.

2. Gain access to the 13/16" Manual Retraction Bolts (one on each mechanism) by raising the STORE-MORE access panel.

3. Remove the Thumb Screws (one on each mechanism) completely by turning them counterclockwise.

4. Using wrench provided, a personal wrench or a tire iron with a 13/16" or 21mm opening rotate either mechanism's Manual Retraction Bolt clockwise 6 complete turns.

5. Move to the second room extension mechanism, rotate the Manual Retraction Bolt clockwise 12 complete turns.

6. Return to the first room extension mechanism and rotate the Manual Retraction Bolt clockwise 12 complete turns.

7. Repeat steps 4 and 5 alternating from mechanism to mechanism rotating each Manual Retraction Bolt 12 complete turns until room is sealed. (DO NOT exceed 15 ft.lbs) Make sure the room does not bind.

8. Replace both Thumb Screws. Leave the manual valve releases open.

IMPORTANT: If at any stage something is not understood or if the room begins to bind DO NOT force the room, contact HWH Customer Service for assistance 1-800-321-3494.

IMPORTANT: DO NOT EXTEND THE ROOM UNTIL THE STEPS BELOW HAVE BEEN COMPLETED!

1. Gain access to the 13/16" Manual Retraction Bolts (one on each mechanism) by raising the STORE-MORE access panel.

2. Remove the Thumb Screws (one on each mechanism) completely by turning them counterclockwise.

3. If needed, using wrench provided, a personal wrench or a tire iron with a 13/16" or 21mm opening rotate either mechanism's Manual Retraction Bolt counterclockwise until resistance is met.

4. Move to the second room extension mechanism and repeat step 3.

5. Replace both Thumb Screws.

6. Close both manual valve releases assigned to the room. Turn the valve release nuts clockwise until snug. **DO NOT over tighten.**

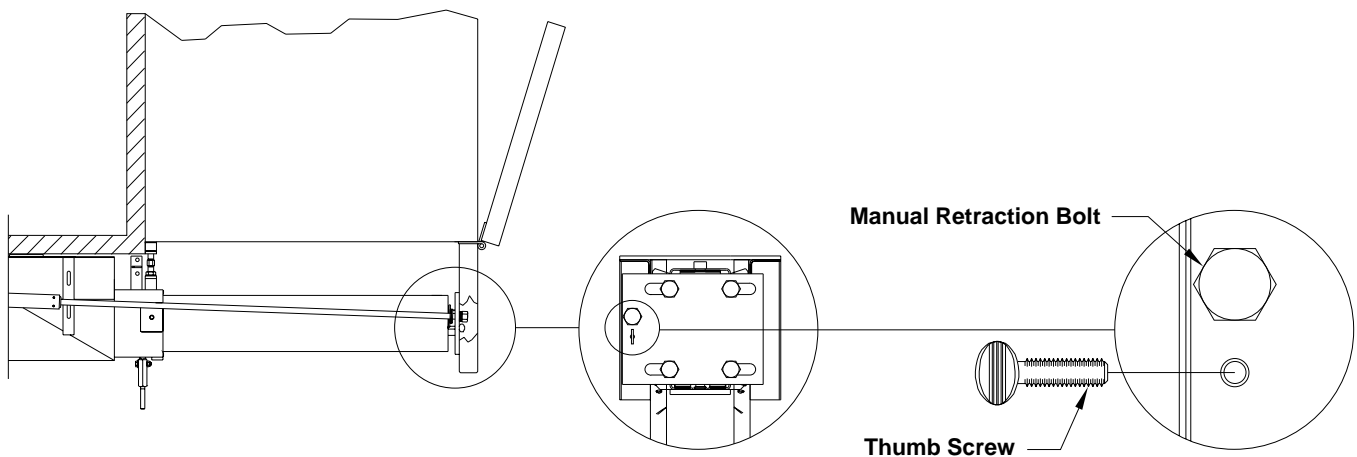
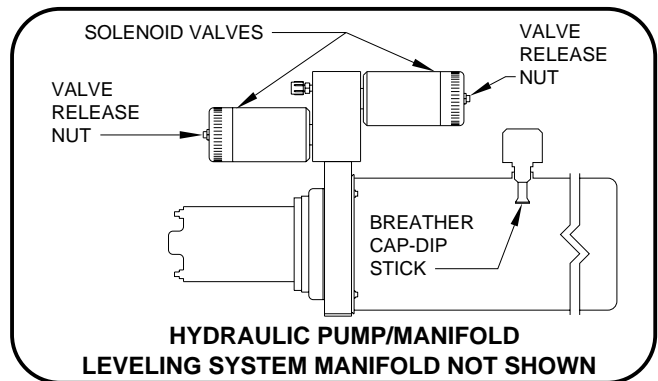

OPERATING PROCEDURES

"X-SLIDE" ROOM EXTENSION MECHANISM

MANUAL ROOM RETRACTION PROCEDURES

1. Determine which extend and retract solenoid valves are assigned to the room. Manually open the valve release nuts for the extend and retract solenoid valves by turning the 1/4" release nuts counter clockwise 4 and 1/2 turns. Turning the nuts more could damage the valves. If equipped with valve release cams, move the cams to the OPEN position.

NOTE: The breather cap dip stick is also a 1/4" nut driver.

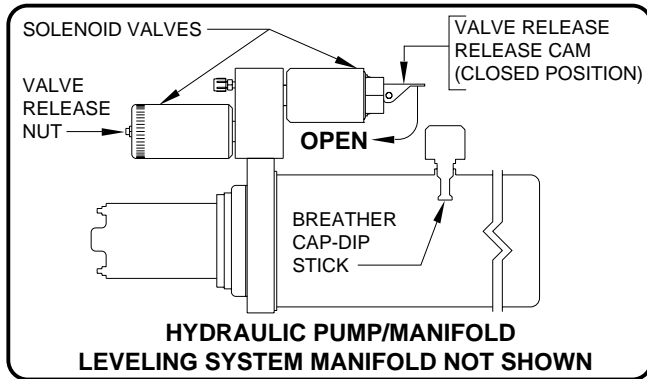

2. Start both threaded rods until resistance is met, one for the front and one for the rear mechanism should be provided.

NOTE: For location of the threaded rods and to access the threaded blocks refer to vehicle manufacturer.

3. **Do Not use an impact wrench.** Using wrench provided, a personal wrench or a tire iron with a 1-1/8" opening rotate either mechanism's threaded rod clockwise 6 complete turns.

4. Move to the other room extension mechanism, rotate the threaded rod clockwise 12 complete turns.

5. Return to the first room extension mechanism and rotate the threaded rod clockwise 12 complete turns.

6. Repeat steps 4 and 5 alternating from mechanism to mechanism rotating each threaded rod 12 complete turns until room is sealed. (DO NOT exceed 15 ft.lbs) Make sure the room does not bind.

IMPORTANT: If at any stage something is not understood or if the room begins to bind DO NOT force the room, contact HWH Customer Service for assistance 1-800-321-3494.

NOTE: Leave the solenoid valves open and the threaded rods in place until the room has been serviced.

IMPORTANT: DO NOT EXTEND THE ROOM UNTIL THE ROOM HAS BEEN SERVICED. ANY SOLENOID VALVES LEFT OPEN SHOULD BE CLOSED AND THE THREADED RODS SHOULD BE COMPLETELY REMOVED.

NOTE: If there is not enough room to remove both threaded rods completely, alternate backing the threaded rods out and slightly extending the room. Be careful to not extend the room so far that the threaded rods impact the coach wall or the mechanism.

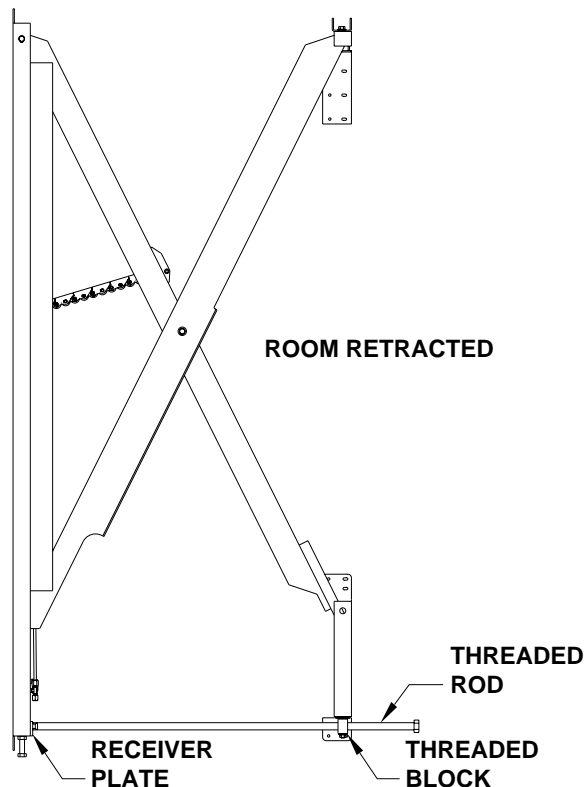
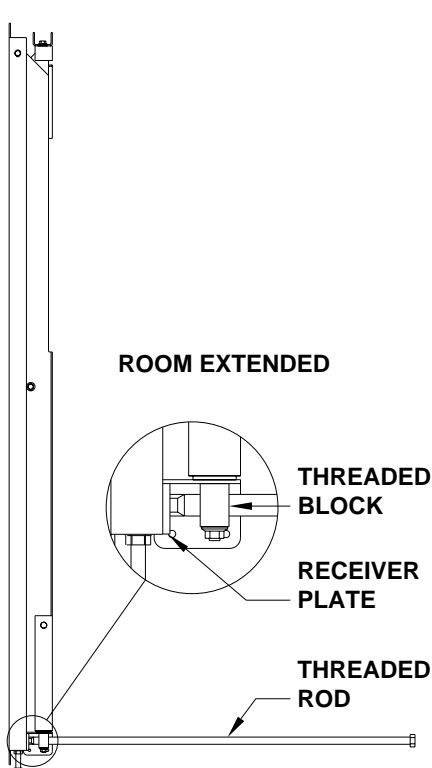

OPERATING PROCEDURES

"UNIVERSAL STRAIGHT OUT" ROOM EXTENSION MECHANISM

MANUAL ROOM RETRACTION PROCEDURES

1. Determine which extend and retract solenoid valves are assigned to the room. Manually open the valve release nuts for the extend and retract solenoid valves by turning the 1/4" release nuts counter clockwise 4 and 1/2 turns. Turning the nuts more could damage the valves. If equipped with valve release cams, move the cams to the OPEN position.

NOTE: The breather cap dip stick is also a 1/4" nut driver.

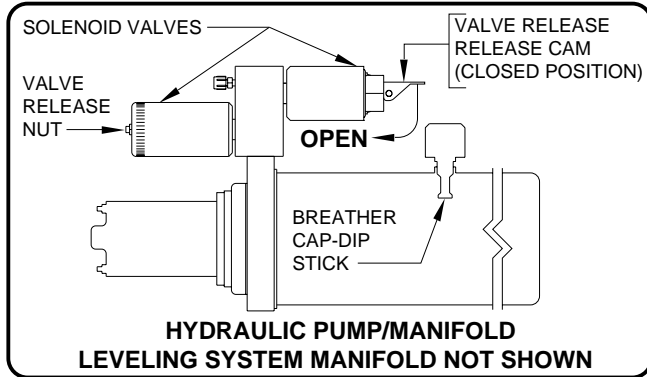

2. Start both threaded rods until resistance is met, one for the front and one for the rear mechanism should be provided.

NOTE: For location of the threaded rods and to access the threaded blocks refer to vehicle manufacturer.

3. **Do Not use an impact wrench.** Using wrench provided, a personal wrench or a tire iron with a 1-1/8" opening rotate either mechanism's threaded rod clockwise 6 complete turns.

4. Move to the other room extension mechanism, rotate the threaded rod clockwise 12 complete turns.

5. Return to the first room extension mechanism and rotate the threaded rod clockwise 12 complete turns.

6. Repeat steps 4 and 5 alternating from mechanism to mechanism rotating each threaded rod 12 complete turns until room is sealed. (DO NOT exceed 15 ft.lbs) Make sure the room does not bind.

IMPORTANT: If at any stage something is not understood or if the room begins to bind DO NOT force the room, contact HWH Customer Service for assistance 1-800-321-3494.

NOTE: Leave the solenoid valves open and the threaded rods in place until the room has been serviced.

IMPORTANT: DO NOT EXTEND THE ROOM UNTIL THE ROOM HAS BEEN SERVICED. ANY SOLENOID VALVES LEFT OPEN SHOULD BE CLOSED AND THE THREADED RODS SHOULD BE COMPLETELY REMOVED.

NOTE: If there is not enough room to remove both threaded rods completely, alternate backing the threaded rods out and slightly extending the room. Be careful to not extend the room so far that the threaded rods impact the coach wall or the mechanism.

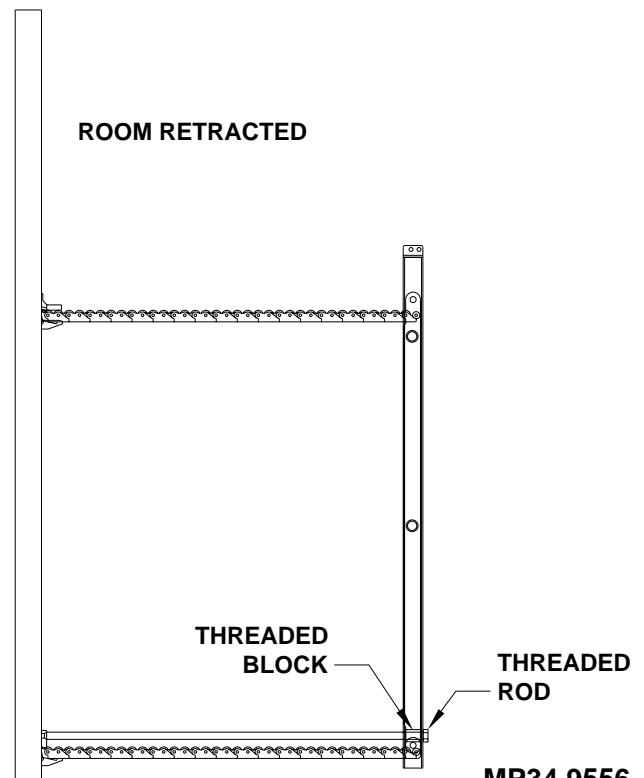
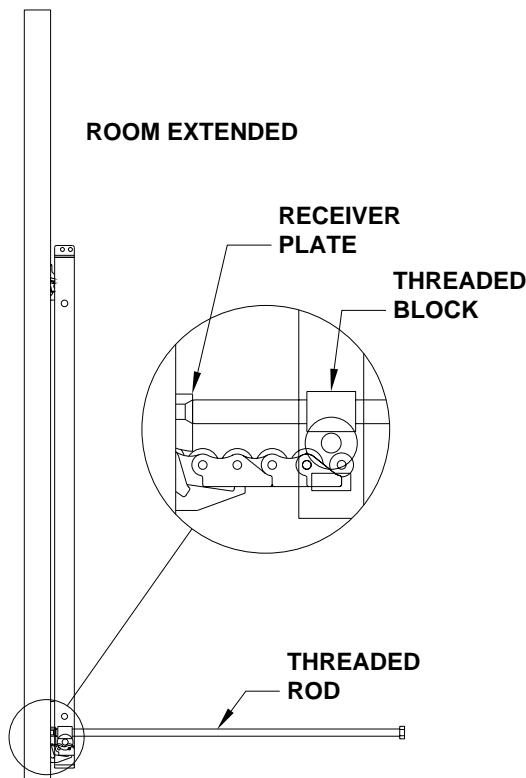

OPERATING PROCEDURES

"UNIVERSAL STRAIGHT OUT" ROOM EXTENSION MECHANISM

MANUAL ROOM RETRACTION PROCEDURES

1. Determine which extend and retract solenoid valves are assigned to the room. Manually open the valve release nuts for the extend and retract solenoid valves by turning the 1/4" release nuts counter clockwise 4 and 1/2 turns. Turning the nuts more could damage the valves. If equipped with valve release cams, move the cams to the OPEN position.

NOTE: The breather cap dip stick is also a 1/4" nut driver.

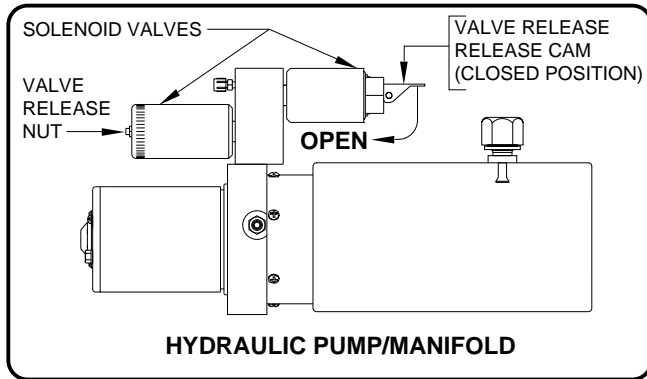

2. Start both threaded rods until resistance is met, one for the front and one for the rear mechanism should be provided.

NOTE: For location of the threaded rods and to access the threaded blocks refer to vehicle manufacturer.

3. **Do Not use an impact wrench.** Using wrench provided, a personal wrench or a tire iron with a 1-1/8" opening rotate either mechanism's threaded rod clockwise 6 complete turns.

4. Move to the other room extension mechanism, rotate the threaded rod clockwise 12 complete turns.

5. Return to the first room extension mechanism and rotate the threaded rod clockwise 12 complete turns.

6. Repeat steps 4 and 5 alternating from mechanism to mechanism rotating each threaded rod 12 complete turns until room is sealed. (DO NOT exceed 15 ft.lbs) Make sure the room does not bind.

IMPORTANT: If at any stage something is not understood or if the room begins to bind DO NOT force the room, contact HWH Customer Service for assistance 1-800-321-3494.

NOTE: Leave the solenoid valves open and the threaded rods in place until the room has been serviced.

IMPORTANT: DO NOT EXTEND THE ROOM UNTIL THE ROOM HAS BEEN SERVICED. ANY SOLENOID VALVES LEFT OPEN SHOULD BE CLOSED AND THE THREADED RODS SHOULD BE COMPLETELY REMOVED.

NOTE: If there is not enough room to remove both threaded rods completely, alternate backing the threaded rods out and slightly extending the room. Be careful to not extend the room so far that the threaded rods impact the coach wall or the mechanism.

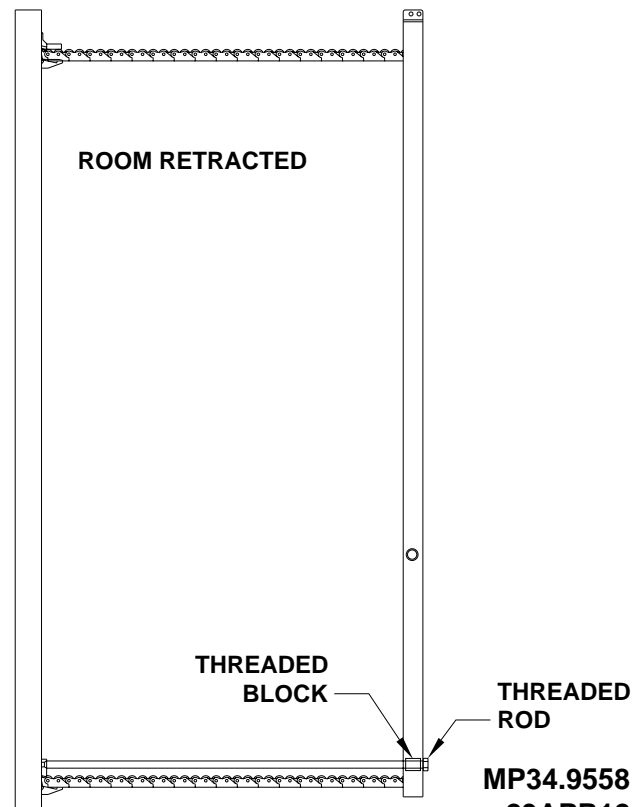
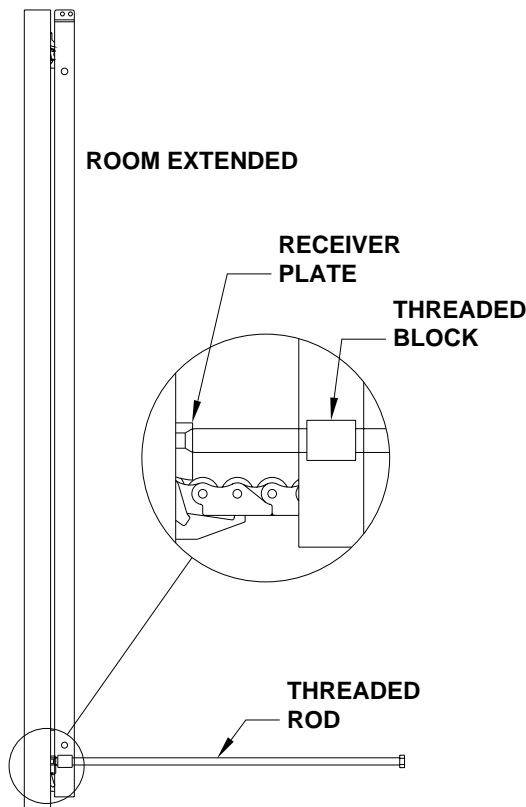

OPERATING PROCEDURES

"UNIVERSAL PLATFORM LEVEL-OUT" ROOM EXTENSION MECHANISM MANUAL ROOM LIFT PROCEDURES

NOTE: Manual room lift procedures must be done before manual room retraction procedures.

1. Determine which synchronizing cylinder controls the room. Manually open the valve release cams for the extend and retract solenoid valves by moving the cams to the "VALVE OPENED" position as shown.

IMPORTANT: RELEASE CAM MIGHT BE ROTATED TO ANY DIRECTION ON THE VALVE. MAKE SURE TO MOVE THE RELEASE CAMS IN THE CORRECT DIRECTION. INCORRECT MOVEMENT OF THE CAMS CAN DAMAGE THE VALVES.

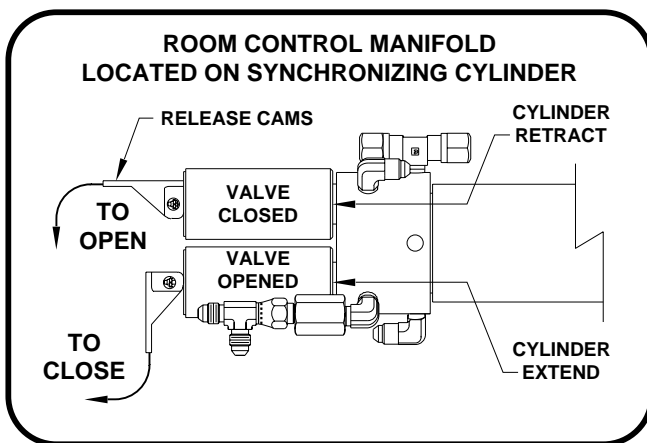

If the pump manifold is equipped with an auxiliary hand pump, you may be able to retract the room by opening only the room retract valve (as labeled by the wiring harness) and operating the hand pump, refer to the **AUXILIARY HAND PUMP OPERATION** page for instructions on the use of the hand pump and valves equipped with a release cam. If the room cannot be retracted with the hand pump, it will be necessary to use the lift bolts and room retract screws.

NOTE: There may be more than one platform lift cylinder assembly. There is a manual lift bolt for each assembly. All lift bolts must be used to lift the room.

2. Use a 13/16 wrench or socket to rotate the lift bolt(s) clockwise until they are seated in the receiver block. **DO NOT USE AN IMPACT WRENCH TO TURN LIFT BOLTS.** Continue to turn the bolt(s) until the room is completely lifted. When there are multiple lift bolts, alternate evenly between all lift bolts, turning each bolt two or three complete turns each time. **Turning one lift bolt without alternating may cause the room to bind.**

3. Leave the valves opened and refer to the next page for room retract procedures.

IMPORTANT: If at any stage something is not understood or if the room begins to bind DO NOT force the room, contact HWH Customer Service for assistance 1-800-321-3494.

DO NOT RETRACT LIFT BOLT UNTIL YOU HAVE READ "EXTENDING ROOM AFTER SERVICE" ON NEXT PAGE.

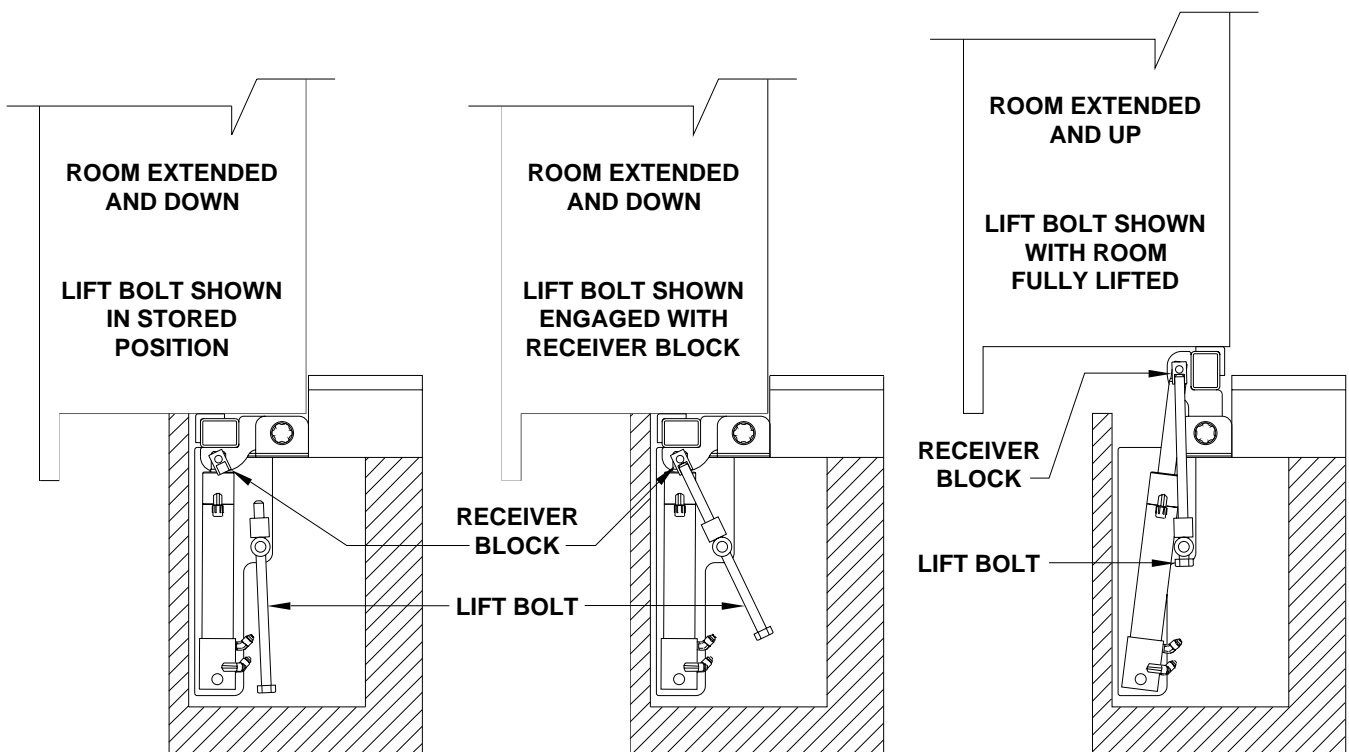

OPERATING PROCEDURES

"UNIVERSAL LEVEL OUT" ROOM EXTENSION MECHANISM

MANUAL ROOM LIFT PROCEDURES

NOTE: Manual room lift procedures must be done before manual room retraction procedures.

1. Determine which extend and retract solenoid valves are assigned to the room. Manually open the valve release nuts for the extend and retract solenoid valves by turning the 1/4" release nuts counter clockwise 4 and 1/2 turns. Turning the nuts more could damage the valves. If equipped with valve release cams, move the cams to the OPEN position.

NOTE: The breather cap dip stick is also a 1/4" nut driver.

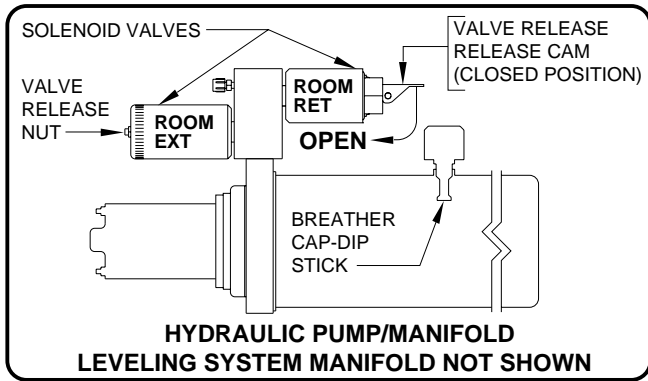

If this manifold is equipped with an auxiliary hand pump, you may be able to retract the room by opening only the room retract valve and operating the hand pump, refer to the AUXILIARY HAND PUMP OPERATION page for

instruction on the use of the hand pump and valves equipped with a release cam. If the room cannot be retracted with the hand pump, it will be necessary to use the lift bolts and room retract screws.

2. Start both room lift bolts until resistance is met, one for the front and one for the rear mechanism should be provided.

NOTE: To locate the room lift access holes and bolts refer to vehicle manufacturer.

3. **Do Not use an impact wrench.** Using a 9/16 wrench alternate between lift bolts turning each 4 full turns each time. Lift the room only as far as is needed to clear the bottom surface of the room over the lift ramps. **As the room is lifted a gap should develop allowing you to view the lift ramps more clearly.**

4. Follow MANUAL ROOM RETRACT PROCEDURES.

IMPORTANT: If at any stage something is not understood or if the room begins to bind DO NOT force the room, contact HWH Customer Service for assistance 1-800-321-3494.

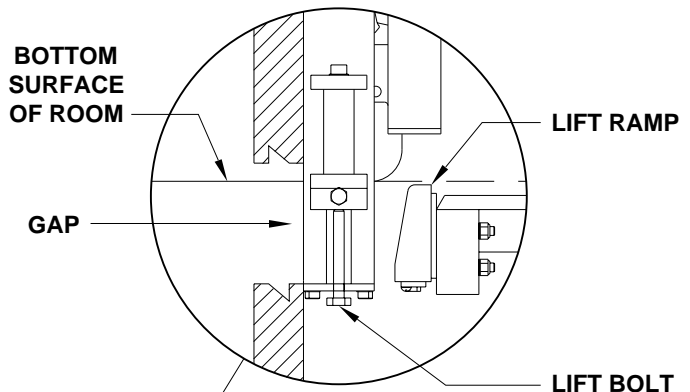
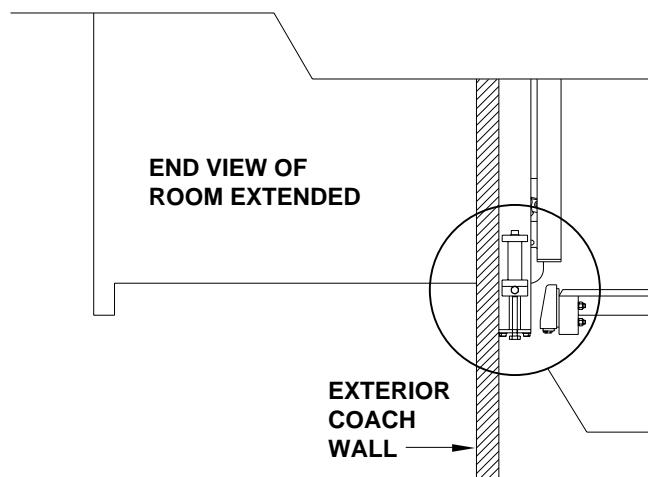
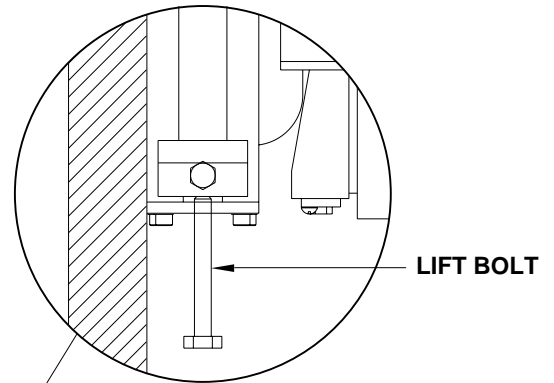
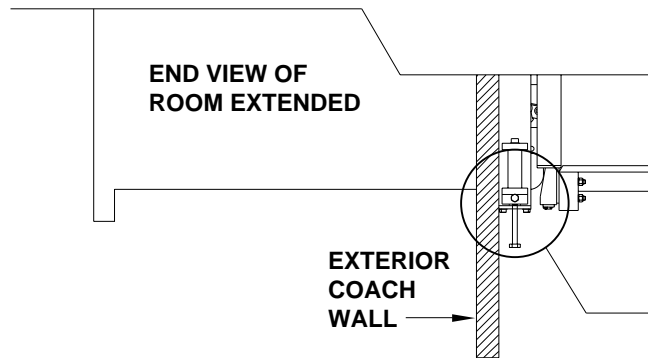

OPERATING PROCEDURES

"UNIVERSAL LEVEL OUT" ROOM EXTENSION MECHANISM

MANUAL ROOM RETRACT PROCEDURES

NOTE: Manual room lift procedures must be done before manual room retraction procedures.

1. Start both threaded rods until resistance is met, one for the front and one for the rear mechanism should be provided.

NOTE: To access the threaded blocks refer to vehicle manufacturer.

2. **Do Not use an impact wrench.** Using wrench provided, a personal wrench or a tire iron with a 1-1/8" opening rotate either mechanism's threaded rod clockwise 6 complete turns.

3. Move to the other room extension mechanism, rotate the threaded rod clockwise 12 complete turns.

4. Return to the first room extension mechanism and rotate the threaded rod clockwise 12 complete turns.

5. Repeat steps 3 and 4 alternating from mechanism to mechanism rotating each threaded rod 12 complete turns until room is sealed. (DO NOT exceed 15 ft.lbs) Make sure the room does not bind.

IMPORTANT: If at any stage something is not understood or if the room begins to bind DO NOT force the room, contact HWH Customer Service for assistance 1-800-321-3494.

NOTE: Leave the solenoid valves open, the lift bolts and threaded rods in place until the room has been serviced.

IMPORTANT: DO NOT EXTEND THE ROOM UNTIL THE ROOM HAS BEEN SERVICED. ANY SOLENOID VALVES LEFT OPEN SHOULD BE CLOSED, LIFT BOLTS AND THREADED RODS SHOULD BE COMPLETELY REMOVED.

NOTE: If there is not enough room to remove both threaded rods completely, alternate backing the threaded rods out and slightly extending the room. Be careful to not extend the room so far that the threaded rods impact the coach wall or the mechanism.

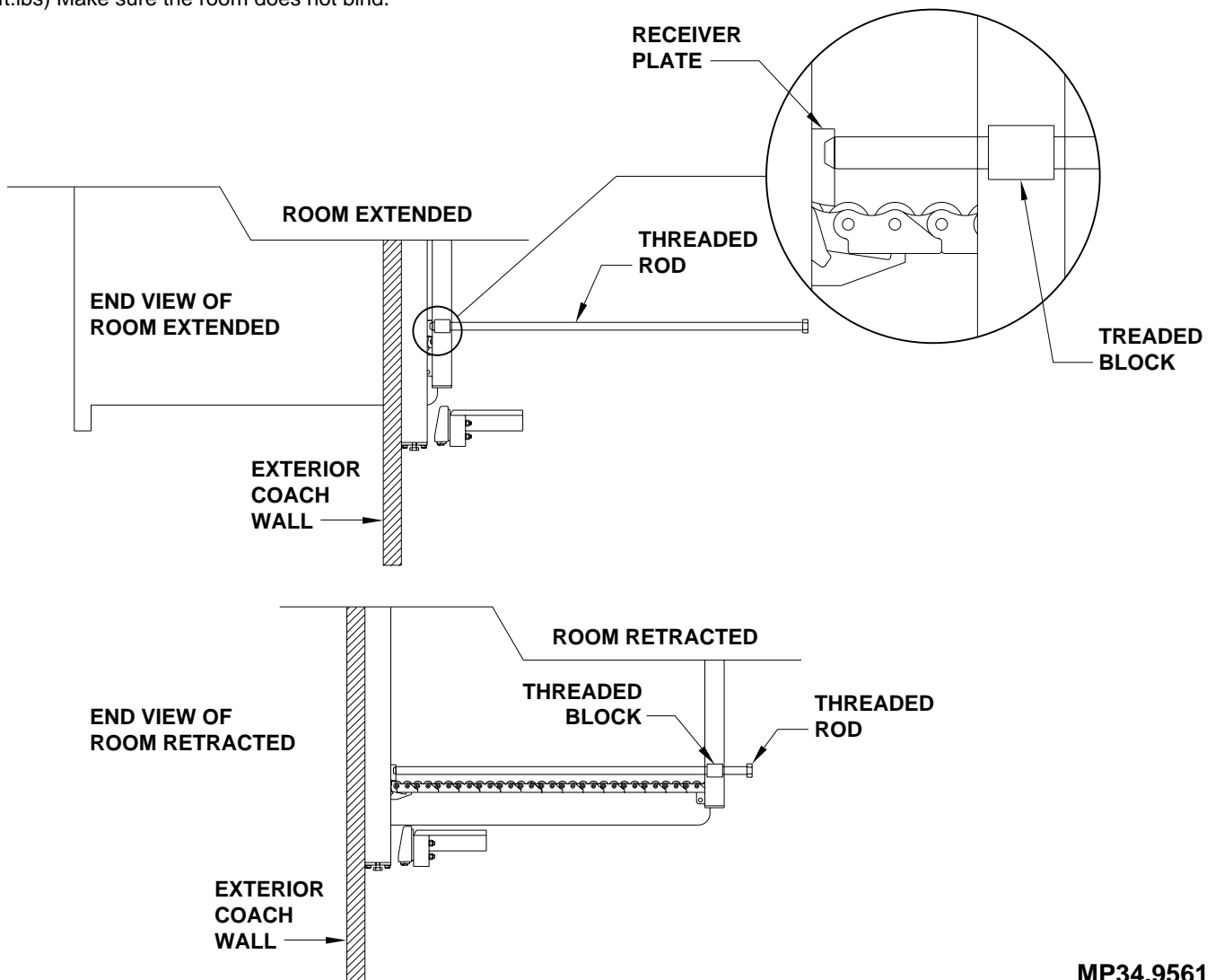

OPERATING PROCEDURES

"UNIVERSAL PLATFORM LEVEL-OUT" ROOM EXTENSION MECHANISM MANUAL ROOM RETRACT PROCEDURES

NOTE: Manual room lift procedures must be done before manual room retraction procedures.

1. Start both threaded rods until resistance is met, one for the front and one for the rear mechanism should be provided.

NOTE: To access the threaded plates refer to vehicle manufacturer.

2. **Do Not use an impact wrench.** Using wrench provided, a personal wrench or a tire iron with a 1-1/8" opening rotate either mechanism's threaded rod clockwise 6 complete turns.

3. Move to the other room extension mechanism, rotate the threaded rod clockwise 12 complete turns.

4. Return to the first room extension mechanism and rotate the threaded rod clockwise 12 complete turns. Repeat steps 3 and 4 alternating from mechanism to mechanism rotating each threaded rod 12 complete turns until room is sealed. (DO NOT exceed 15 ft.lbs) Make sure the room does not bind.

IMPORTANT: If at any stage something is not understood or if the room begins to bind DO NOT force the room, contact HWH Customer Service for assistance 1-800-321-3494.

NOTE: Leave the solenoid valves open, the lift bolts and threaded rods in place until the room has been serviced.

EXTENDING ROOM AFTER SERVICE

1. **Room lift bolts should not be retracted yet.** Push and hold the room switch to "RETRACT" for 5 to 10 seconds.

IMPORTANT: DO NOT EXTEND THE ROOM UNTIL THE ROOM HAS BEEN SERVICED. ANY SOLENOID VALVES LEFT OPEN SHOULD BE CLOSED. THE THREADED RODS SHOULD BE COMPLETELY REMOVED BEFORE ROOM IS FULLY EXTENDED. If there is not enough room to remove both threaded rods completely, alternate backing the threaded rods out and slightly extending the room. Be careful to not extend the room so far that the threaded rods impact the coach wall or the mechanism.

2. Push the room switch to "EXTEND" until the room is within 1 inch of being fully extended. Threaded rods should be completely removed at this time. **Do not allow room to bind.**

3. Retract all lift bolts completely. If room starts to drop, alternate between lift bolts evenly while turning lift bolts.

4. After lift bolts are retracted, push room switch to "EXTEND" until room is fully extended and down. If room dropped while retracting lift bolts, push room switch to "EXTEND" for 5 to 10 seconds.

5. Retract room with room switch.

IMPORTANT: If at any stage something is not understood or if the room begins to bind DO NOT force the room, contact HWH Customer Service for assistance 1-800-321-3494.

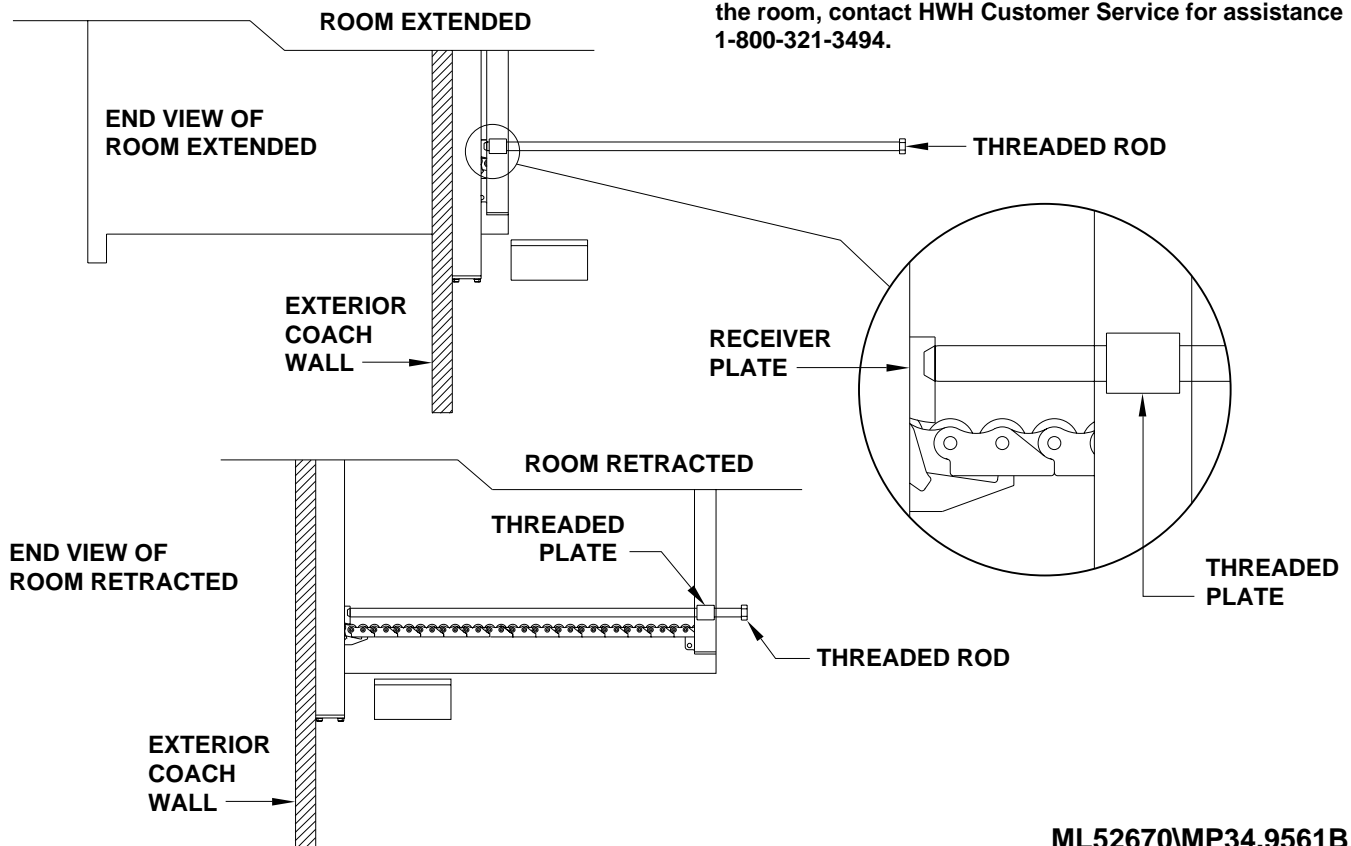

OPERATING PROCEDURES
UNIVERSAL LEVEL IN/LEVEL OUT ROOM EXTENSION MECHANISM
MANUAL ROOM RETRACTION PROCEDURES - SPLINED TORSION SHAFT
PAGE 1 OF 2

In the event of a hydraulic failure, including the hand pump, if so equipped, the room and floor can be manually retracted.

IMPORTANT: KEEP PEOPLE CLEAR OF THE ROOM WHEN MANUALLY RETRACTING THE ROOM. MAKE SURE THERE ARE NO OBJECTS SUCH AS CARPET, CHAIRS, ETC. BLOCKING OR INTERFERING WITH THE MOVEMENT OF THE FLOOR OR ROOM.

To manually retract room, first the floor must be completely lowered. The floor raise / lower mechanism must be accessed to accomplish this. An area closest to the floor lift cylinder is the best area to use. A spline wrench which will be needed to turn the main mechanism spline shaft is wire tied to the main floor lift cylinder.

1. Determine which synchronizing cylinder controls the room. Open both valves by moving the valve release cam to the open position as shown in the following diagram.

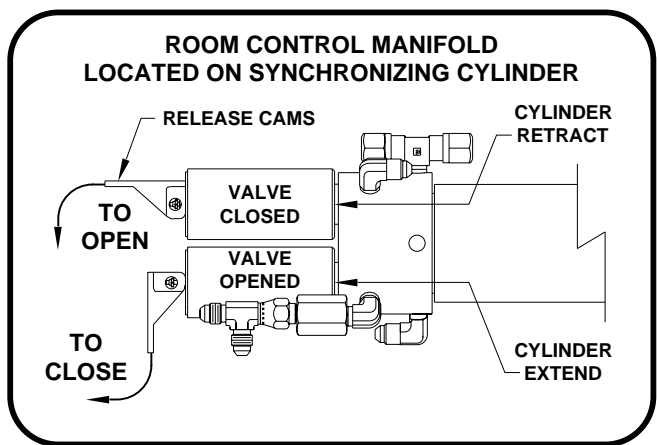

IMPORTANT: ONLY MOVE THE RELEASE CAM IN THE DIRECTION SHOWN. MOVING THE CAM IN THE OPPOSITE DIRECTION CAN DAMAGE THE VALVES.

2. Locate the pressure control valve. This valve must be opened to lower the floor. The pressure control valve is wire tied to the synchronizing cylinder or mounted directly to the main floor lift cylinder. (See the hydraulic diagram or contact HWH Corporation) The end of the valve has a 1/4" release nut. Use a 1/4" nut driver to turn the nut 4 & 1/2" turns counterclockwise. DO NOT turn the nut more than 5 turns or damage to the valve can occur.

3. Access the splined shaft as close to the main floor lift cylinder as possible. (See floor lift mechanism diagram.)

4. Use the spline wrench provided, to rotate the splined shaft in the direction shown in the floor lift mechanism diagram. The floor lift cylinder should extend as the floor lowers to the store position.

5. When the floor is completely lowered, the room can be retracted. Proceed to page 2 for manual room retraction instructions.

NOTE: The floor should not be raised hydraulically or manually until the system has been serviced.

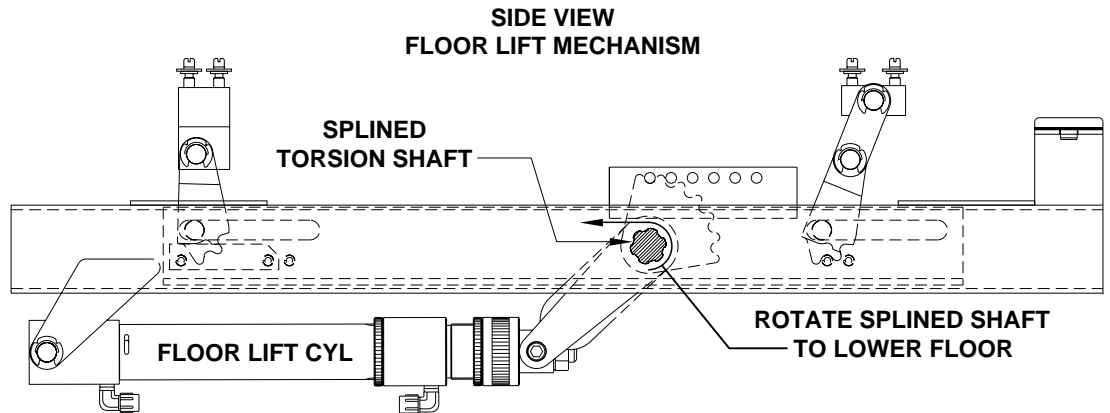
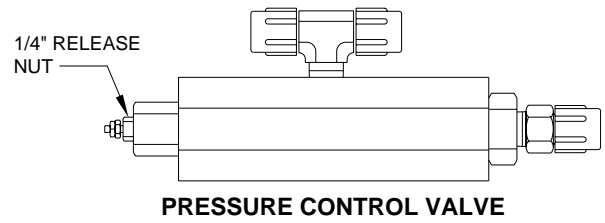

OPERATING PROCEDURES

UNIVERSAL LEVEL IN/LEVEL OUT ROOM EXTENSION MECHANISM

MANUAL ROOM RETRACTION PROCEDURES - SPLINED TORSION SHAFT

PAGE 2 OF 2

1. After the floor is completely lowered, the room can be retracted. Leave the solenoid valves open and proceed to step 2.

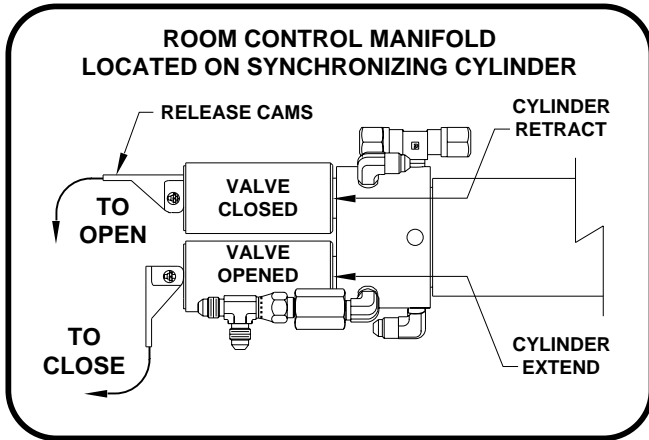

2. Start both threaded rods until resistance is met, one for the front and one for the rear mechanism should be provided.

NOTE: To access the threaded blocks refer to vehicle manufacturer.

3. **Do Not use an impact wrench.** Using wrench provided, a personal wrench or a tire iron with a 1-1/8" opening rotate either mechanism's threaded rod clockwise 6 complete turns.

4. Move to the other room extension mechanism, rotate the threaded rod clockwise 12 complete turns.

5. Return to the first room extension mechanism and rotate the threaded rod clockwise 12 complete turns.

6. Repeat steps 4 and 5 alternating from mechanism to mechanism rotating each threaded rod 12 complete turns until room is sealed. (DO NOT exceed 15 ft.lbs) Make sure the room does not bind.

IMPORTANT: If at any stage something is not understood or if the room begins to bind DO NOT force the room, contact HWH Customer Service for assistance 1-800-321-3494.

NOTE: Leave the solenoid valves open and the threaded rods in place until the room has been serviced.

IMPORTANT: DO NOT EXTEND THE ROOM UNTIL THE ROOM HAS BEEN SERVICED. ANY SOLENOID VALVES LEFT OPEN SHOULD BE CLOSED AND THE THREADED RODS SHOULD BE COMPLETELY REMOVED.

NOTE: If there is not enough room to remove both threaded rods completely, alternate backing the threaded rods out and slightly extending the room. Be careful to not extend the room so far that the threaded rods impact the coach wall or the mechanism.

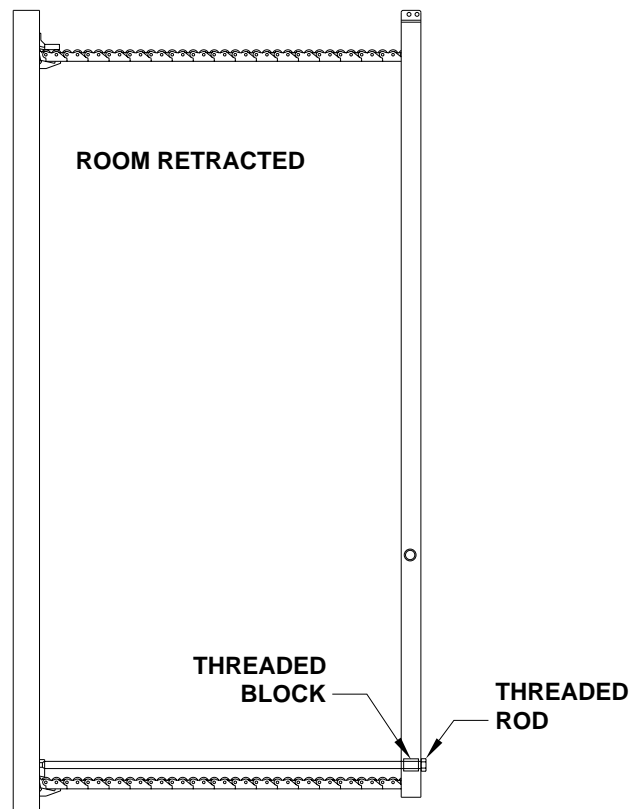
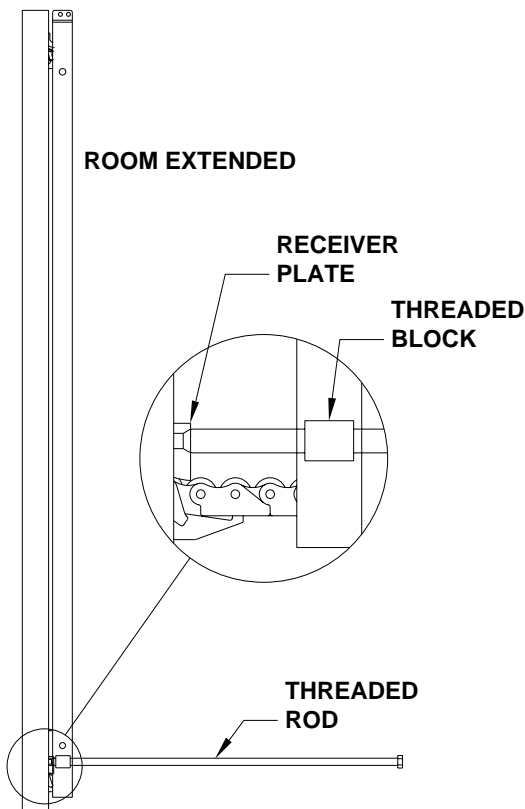

OPERATING PROCEDURES

"UNIVERSAL STRAIGHT OUT" ROOM EXTENSION MECHANISM

MANUAL ROOM RETRACTION PROCEDURES - VALVES WITH RELEASE CAMS

1. Determine which synchronizing cylinder controls the room. Manually open the valve release cams for the extend and retract solenoid valves by moving the valve release cam to the open position.

NOTE: The valve release cam might be rotated in any direction on the valve. Pushing the release cam in the wrong direction could damage the valve.

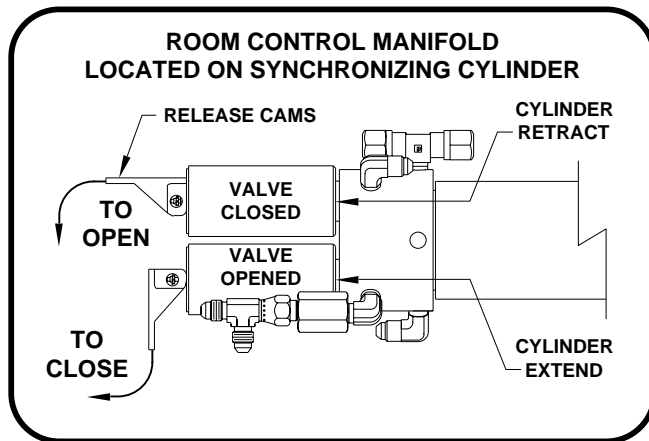

2. Start both threaded rods until resistance is met, one for the front and one for the rear mechanism should be provided.

NOTE: To access the threaded blocks refer to vehicle manufacturer.

3. **Do Not use an impact wrench.** Using wrench provided, a personal wrench or a tire iron with a 1-1/8" opening rotate either mechanism's threaded rod clockwise 6 complete turns.

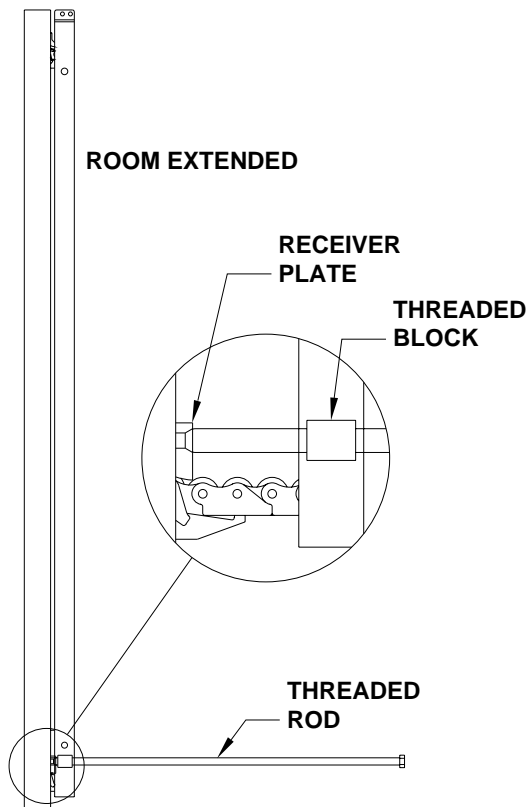

4. Move to the other room extension mechanism, rotate the threaded rod clockwise 12 complete turns.

5. Return to the first room extension mechanism and rotate the threaded rod clockwise 12 complete turns.

6. Repeat steps 4 and 5 alternating from mechanism to mechanism rotating each threaded rod 12 complete turns until room is sealed. (DO NOT exceed 15 ft.lbs) Make sure the room does not bind.

IMPORTANT: If at any stage something is not understood or if the room begins to bind DO NOT force the room, contact HWH Customer Service for assistance 1-800-321-3494.

NOTE: Leave the solenoid valves open and the threaded rods in place until the room has been serviced.

IMPORTANT: DO NOT EXTEND THE ROOM UNTIL THE ROOM HAS BEEN SERVICED. ANY SOLENOID VALVES LEFT OPEN SHOULD BE CLOSED AND THE THREADED RODS SHOULD BE COMPLETELY REMOVED.

NOTE: If there is not enough room to remove both threaded rods completely, alternate backing the threaded rods out and slightly extending the room. Be careful to not extend the room so far that the threaded rods impact the coach wall or the mechanism.

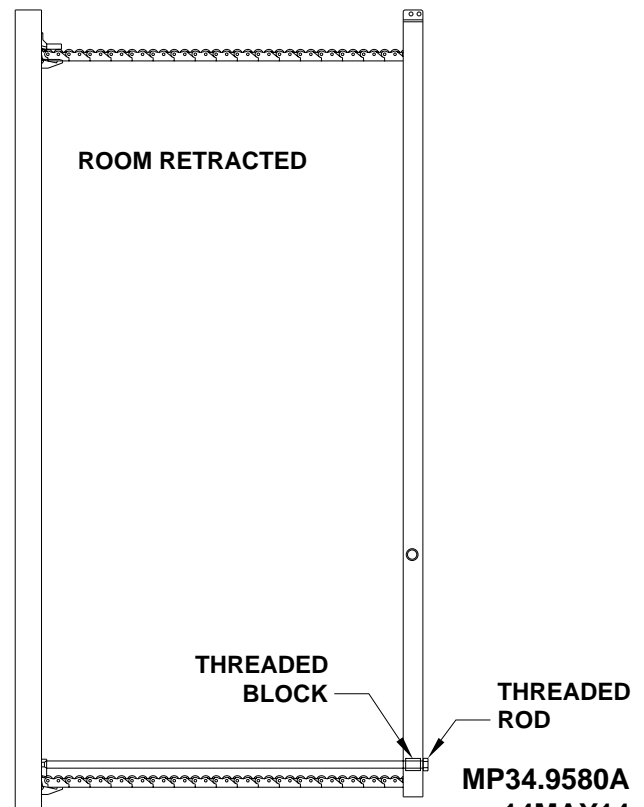

INFORMATION INSERT

HYDRAULIC SOLENOID VALVE

IDENTIFICATION - MANUAL OPERATIONS - REPLACEMENT

REPLACEMENT VALVES MAY HAVE A VALVE RELEASE NUT OR RELEASE CAM

SOLENOID VALVES WITH CAM RELEASE

The cam release style valves are direct replacements for all previous styles of HWH hydraulic solenoid valves.

Valve size and voltage are still factors to be considered when replacing any HWH hydraulic solenoid valve. Replace a small style 12 volt valve with a small style 12 volt valve. Replace a large style 12 volt valve with a large style 12 volt valve. This is true for 24 volt valves also.

Valve installation has not changed, simply turn out the old valve, confirm that no o-ring debris has been left in the manifold block and turn in the new valve.

After installing the valve and without creating stress on the wires at the point where they exit the valve body. Use a wire tie to secure the wires to the valve body to keep the wires from being pinched beneath the cam mechanism during operation.

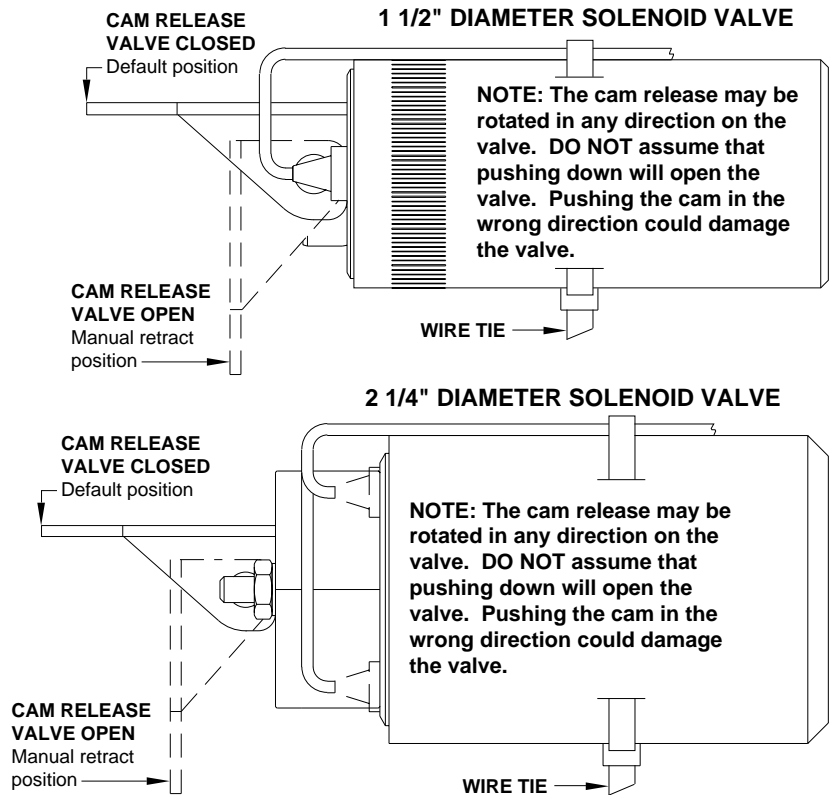

SOLENOID VALVES WITH 1/4" NUT RELEASE

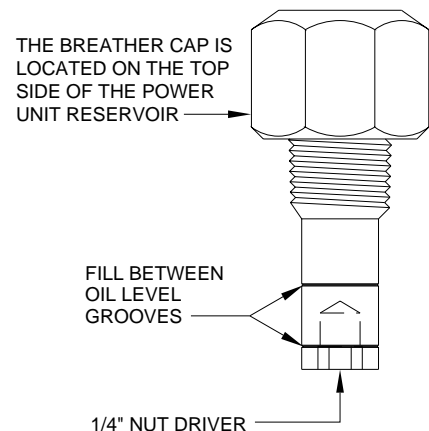
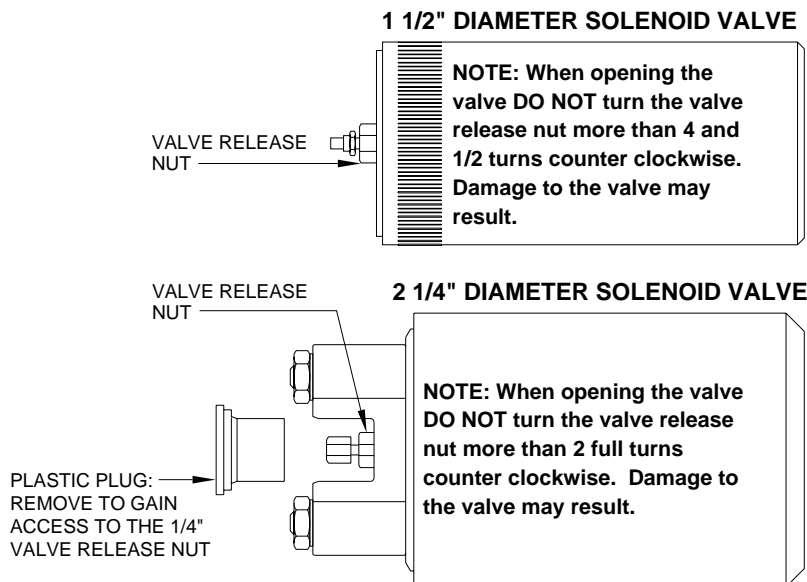

IMPORTANT: PRIOR TO REMOVING THE BREATHER CAP, EITHER TO CHECK THE OIL LEVEL OR TO USE 1/4" NUT DRIVER, CLEAN ANY DEBRIS FROM THE TOP OF THE RESERVOIR. BEFORE RETURNING THE BREATHER CAP TO THE RESERVOIR, REMOVE ANY PAINT CHIPS OR OTHER DEBRIS FROM THE DIPSTICK INCLUDING DEBRIS INSIDE THE 1/4" NUT DRIVER.